











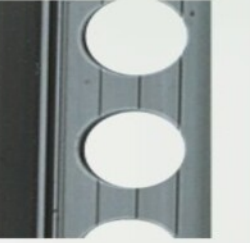







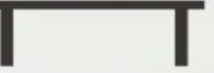

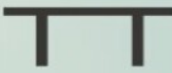

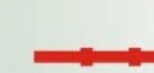







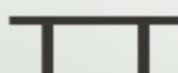



	
產品編號 <b>PH122</b> H=7 R=20 L=20	產品編號 <b>PH112</b> H=3.6 R=20 L=20	產品編號 <b>PH222</b> H=7 R=20 L=20	產品編號 <b>PH22C</b> H=3.6 R=20 L=20	產品編號 <b>PH333</b> H=7 R=20 L=20	產品編號 <b>PH33C</b> H=3.6 R=20 L=20	產品編號 <b>PQL11</b> H=7 W=20	
							
							
產品編號 <b>PQL10</b> H=3.6 W=20	產品編號 <b>PL110</b> H=7 W=20	產品編號 <b>PL100</b> H=3.6 W=20	產品編號 <b>PH102</b> 2cm x 1cm	產品編號 <b>PH102B</b> 2cm x 0.5cm	產品編號 <b>PH101</b> 1cm x 1cm	產品編號 <b>PH101B</b> 1cm x 0.5cm	產品編號 <b>PL001</b> H=1.7 W=16
							
							
產品編號 <b>PH175</b> 1cmx0.75cm	產品編號 <b>GV30</b> 3cm x 1cm	產品編號 <b>GV20</b> 2.5cmx1cm	產品編號 <b>GV15</b> 2cm x1cm	產品編號 <b>GV10</b> 1.5cm x0.7cm	產品編號 <b>GC30</b> 3cm x 1cm	產品編號 <b>GC25</b> 2.5cmx1cm	
							
							
6x3	5x3	4x3	4x2	3x2			

# 丸型斬石條

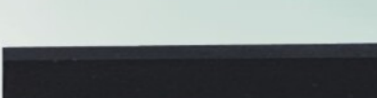

簡介：

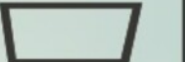
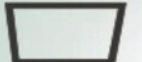
在施作抿石、洗石、斬石、磨石工程時，塗抹石礫前，可利用此類產品黏貼於牆角，以頂點作為整平基準線。

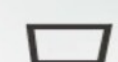
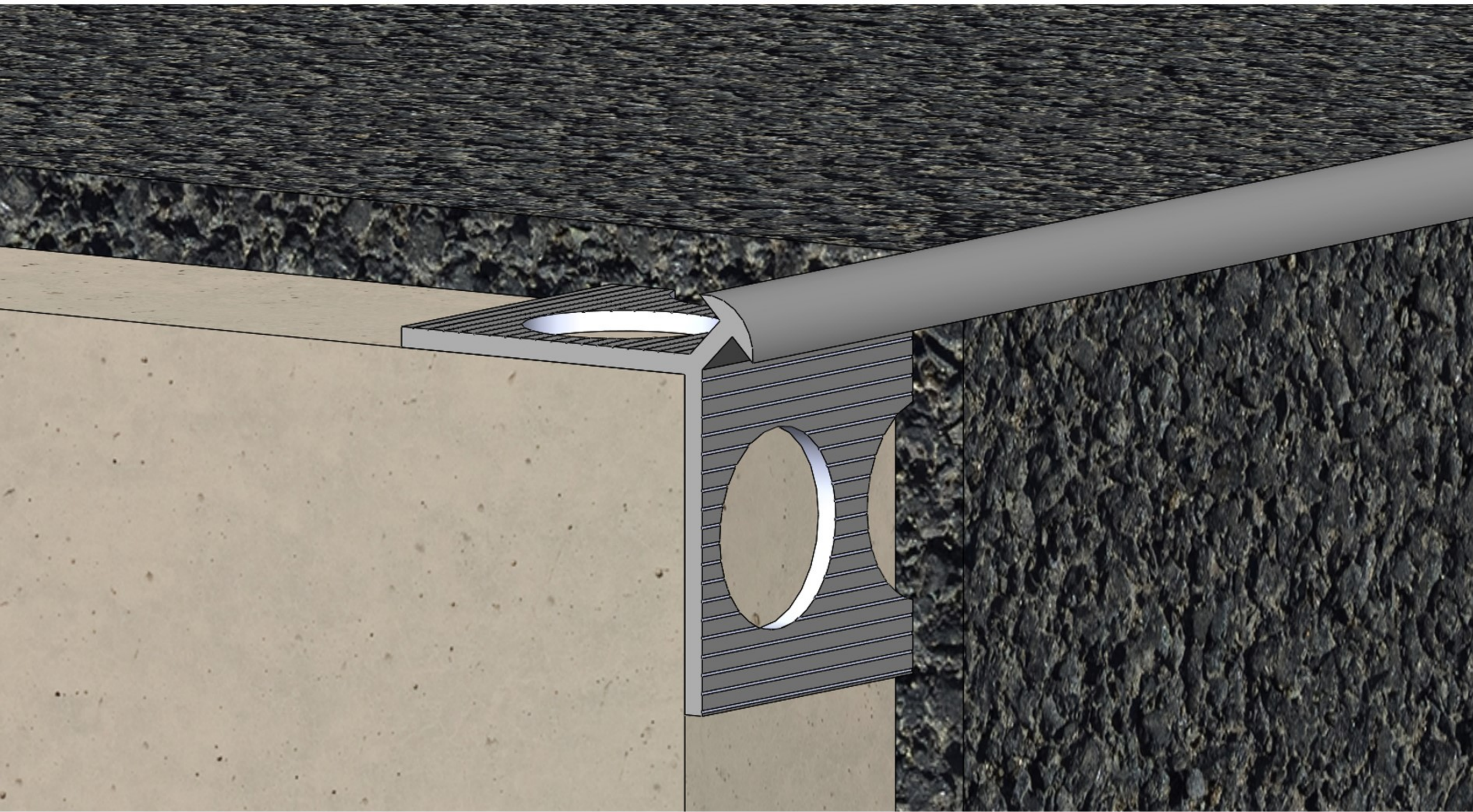
特色：

提高抿石、洗石、斬石、磨石等工法的施工速度、降低成本，並使成品更加美觀

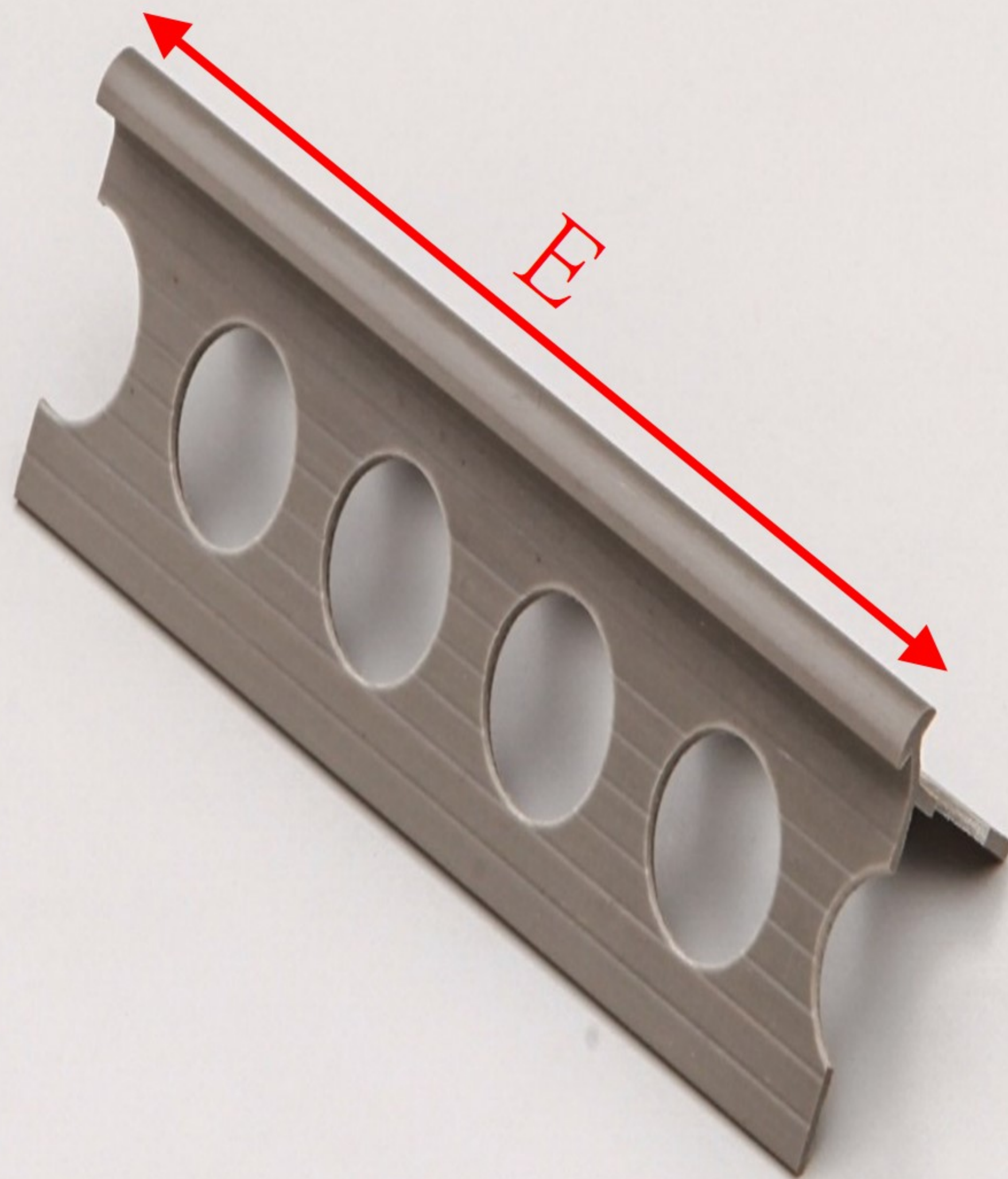
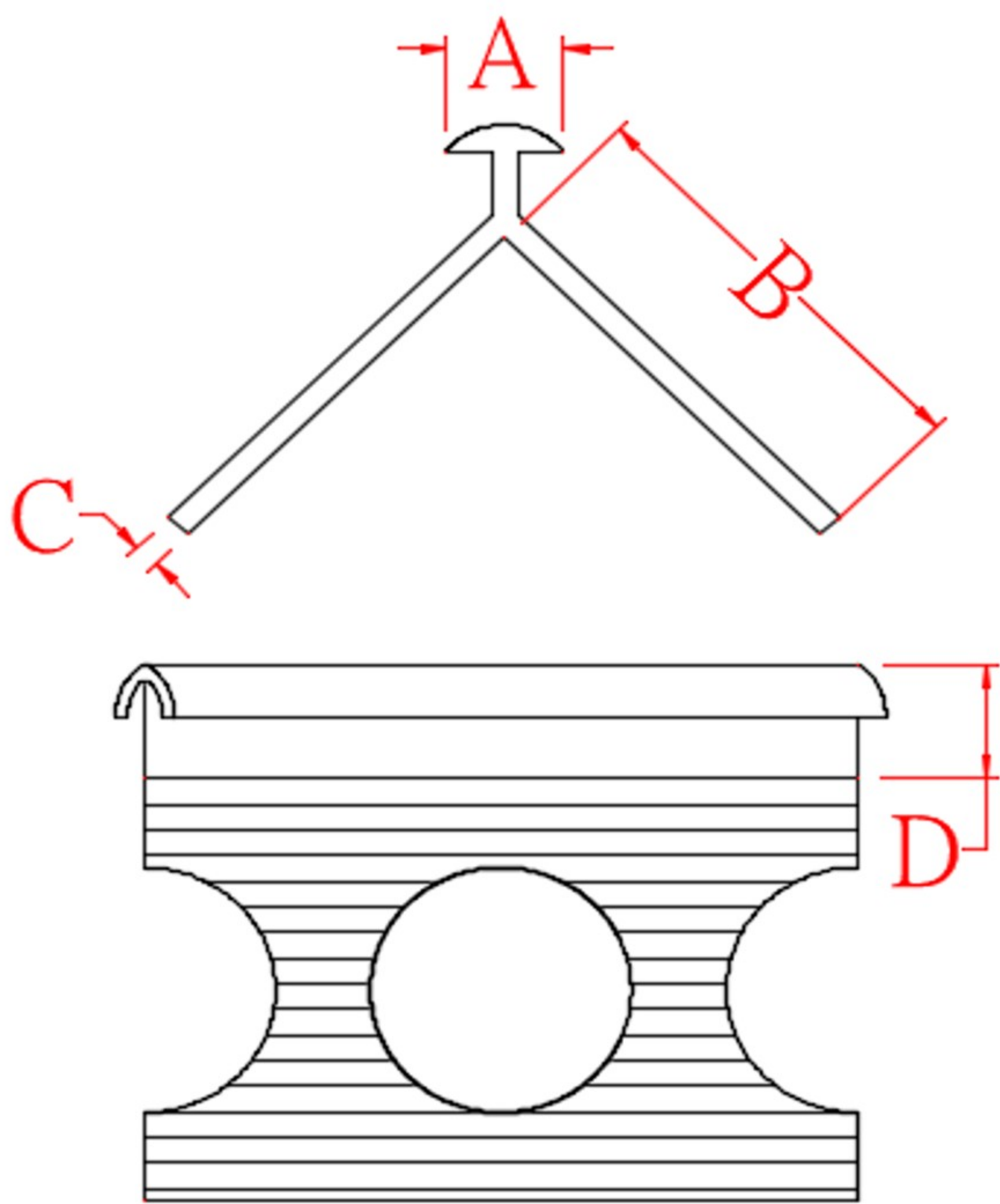

	A(mm)	B(mm)	C(mm)	D(mm)	E(m)
PH112	5	19	1.15	5	1.8
PH122	4.8	20	1.2	10	1.8

# A型斬石條

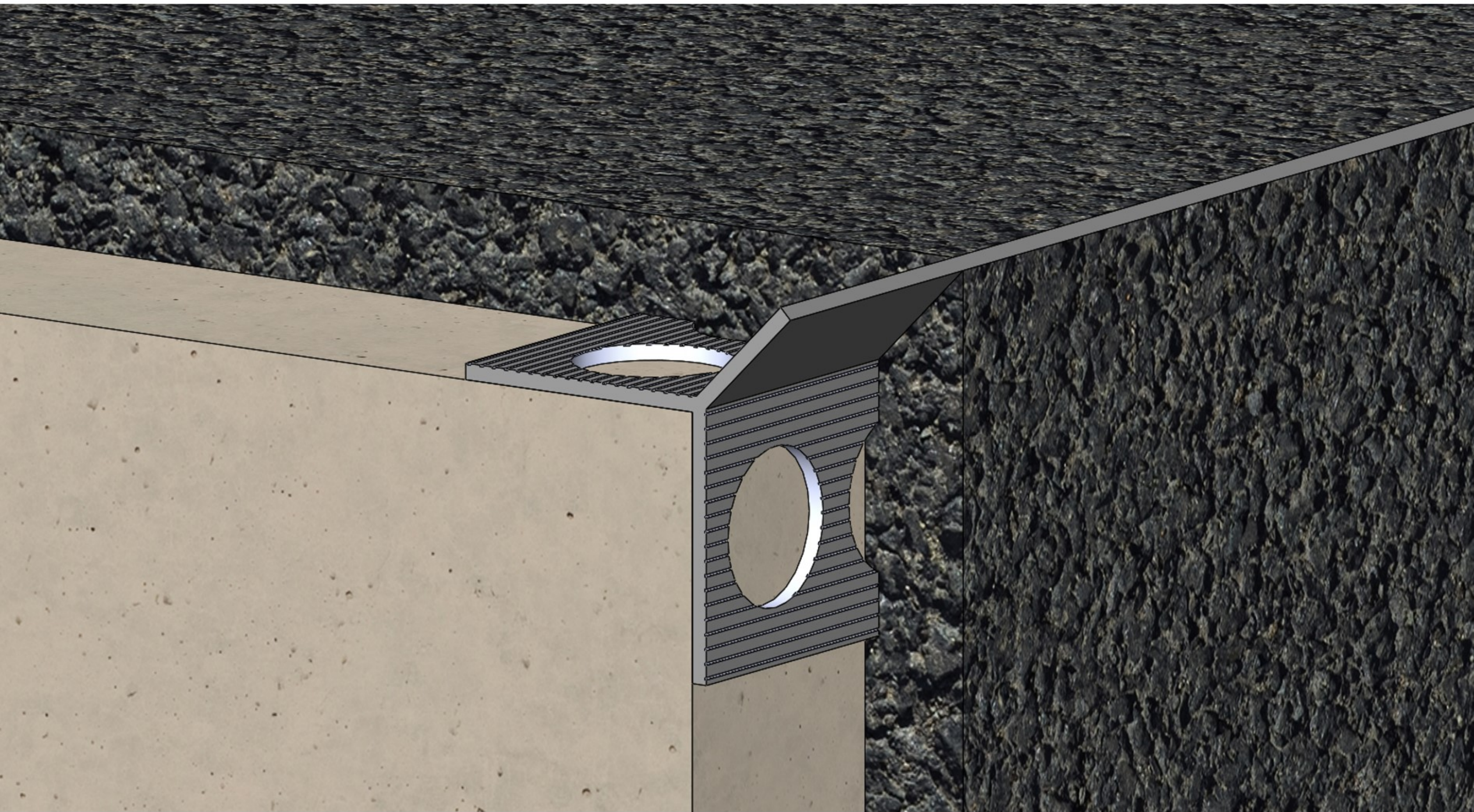

簡介：

在施作抿石、洗石、斬石、磨石工程時，塗抹石礫前，可利用此類產品黏貼於牆角，以頂點作為整平基準線。

特色：

提高抿石、洗石、斬石、磨石等工法的施工速度、降低成本，並使成品更加美觀

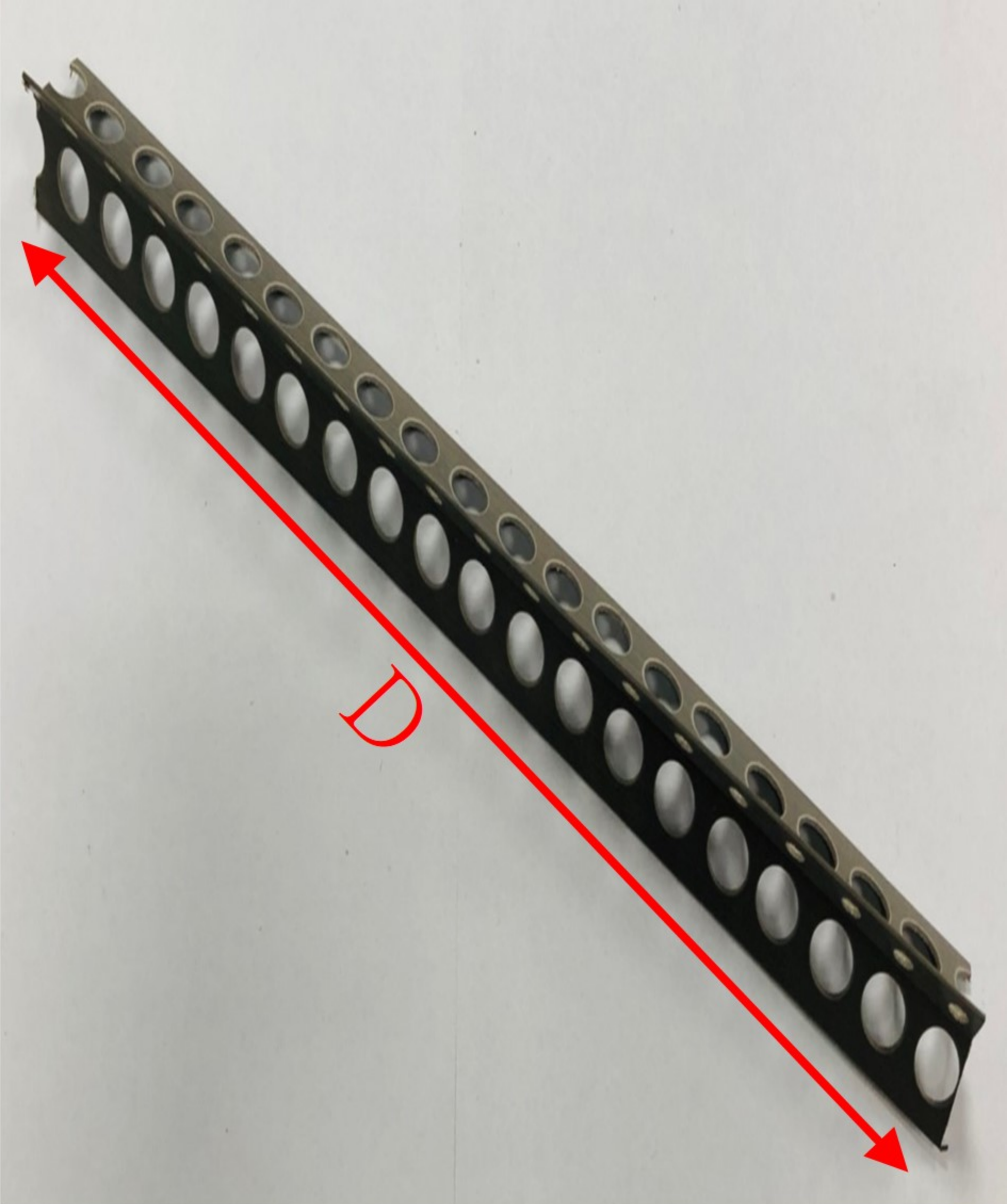
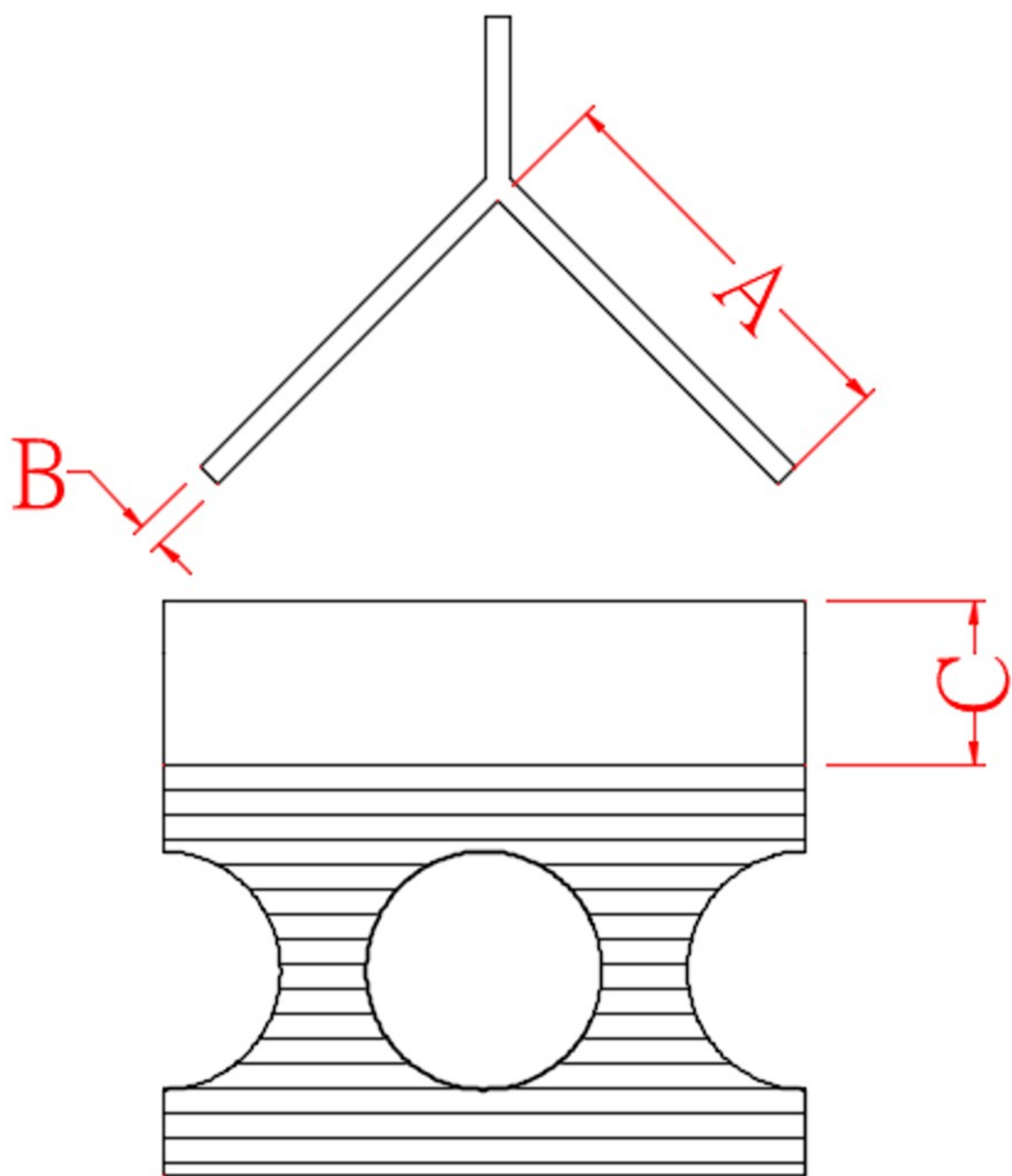

	A(mm)	B(mm)	C(mm)	D(m)
--	-------	-------	-------	------

PH222

18.8

1.15

10.9

1.8

PH22C

19

1.15

7.5

1.8

# 齒痕斬石條

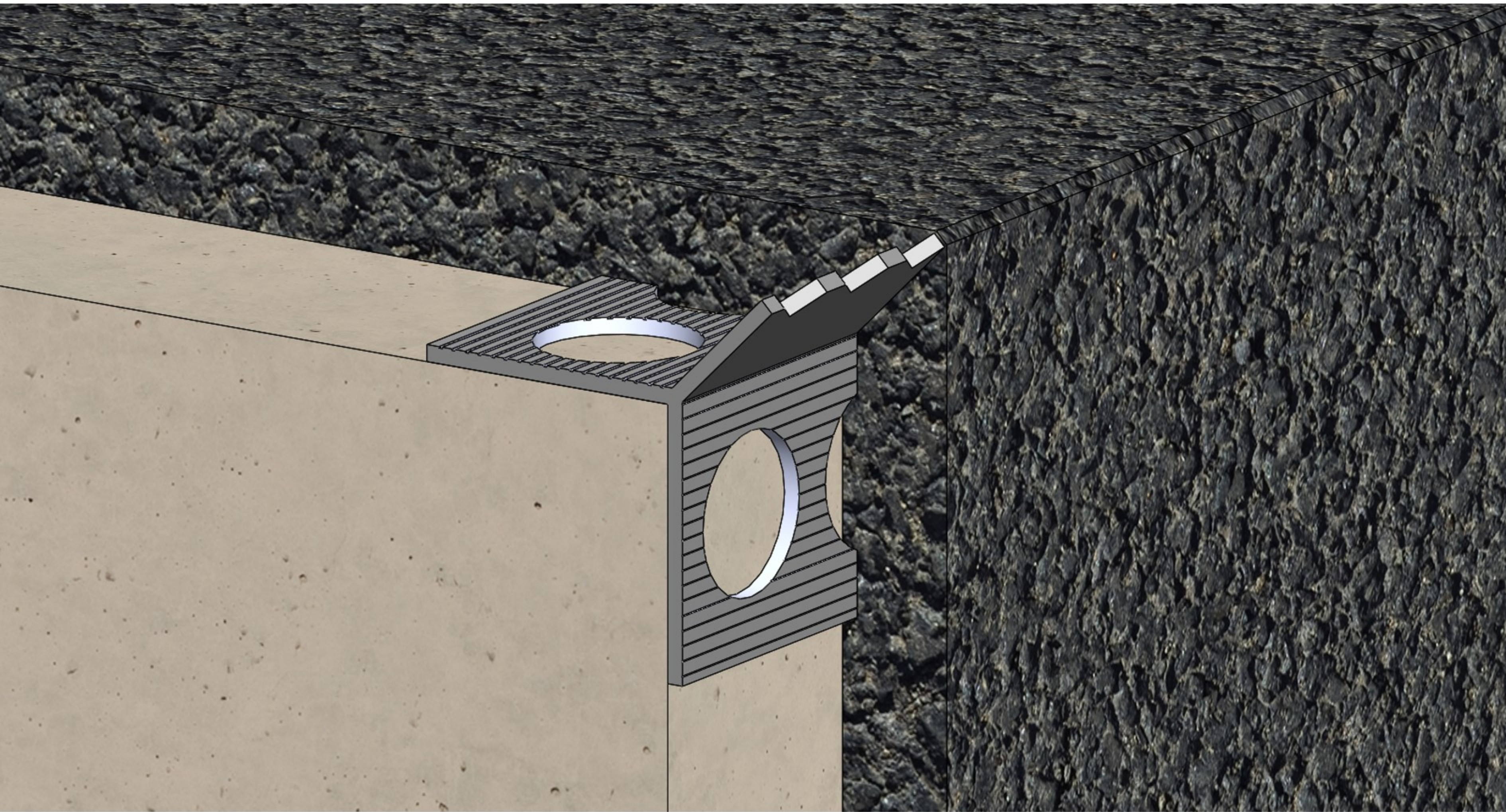

簡介：

在施作抿石、洗石、斬石、磨石工程時，塗抹石礫前，可利用此類產品黏貼於牆角，以頂點作為整平基準線。

特色：

提高抿石、洗石、斬石、磨石等工法的施工速度、降低成本，並使成品更加美觀

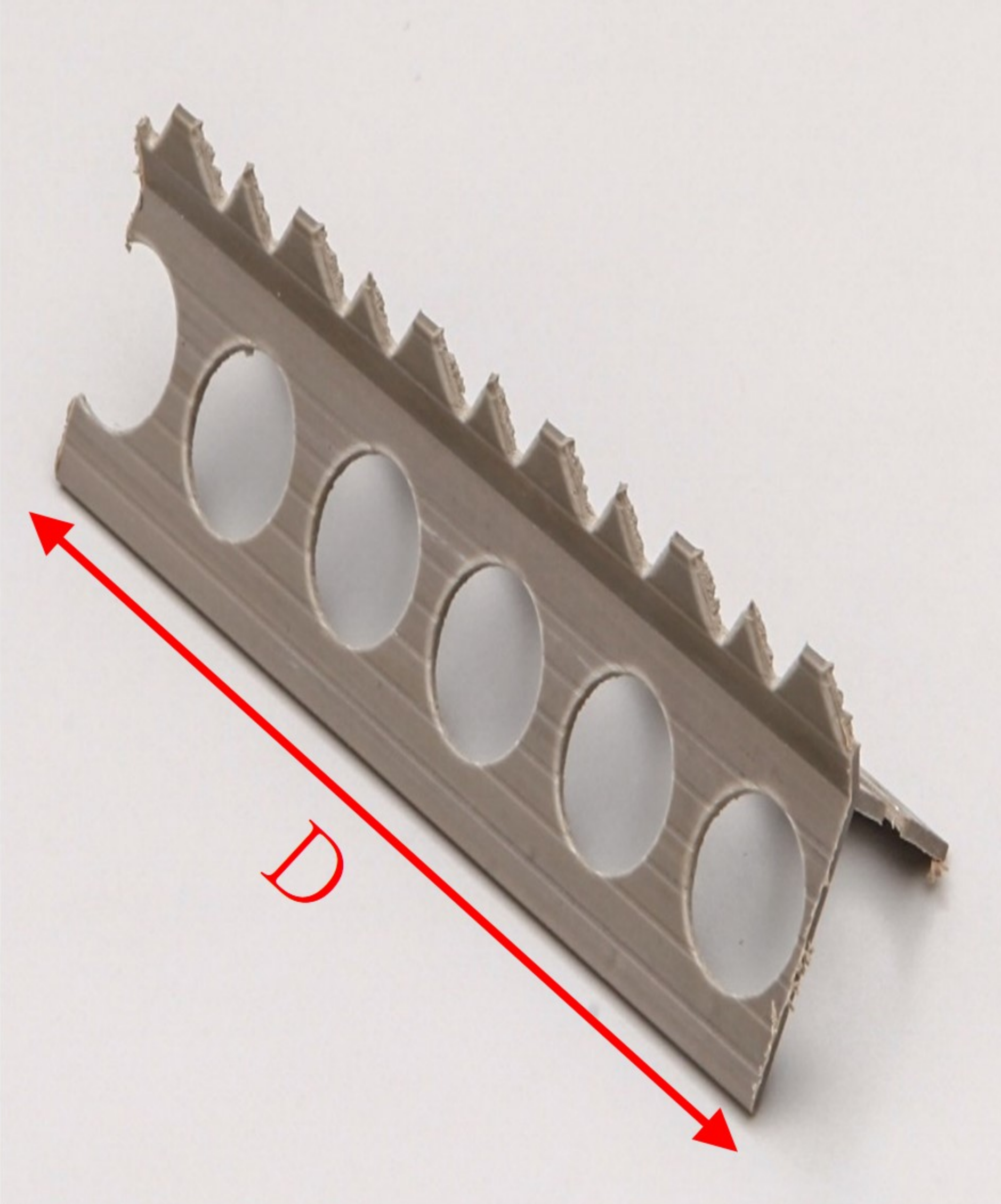
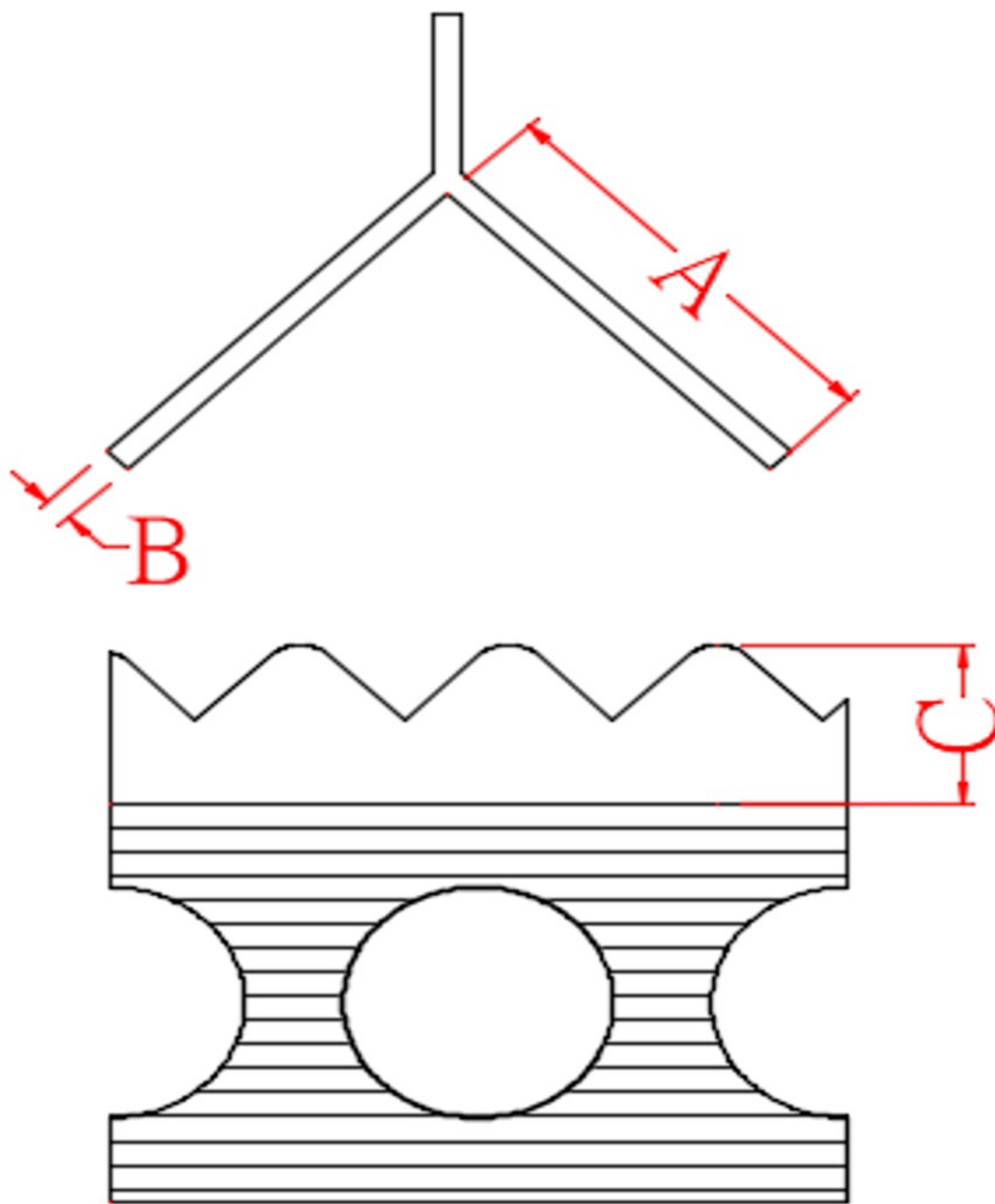

A(mm)

B(mm)

C(mm)

D(m)

PH333

18.8

1.15

10.9

1.8

PH33C

18.5

1.15

7.5

1.8

# ㄇ型條

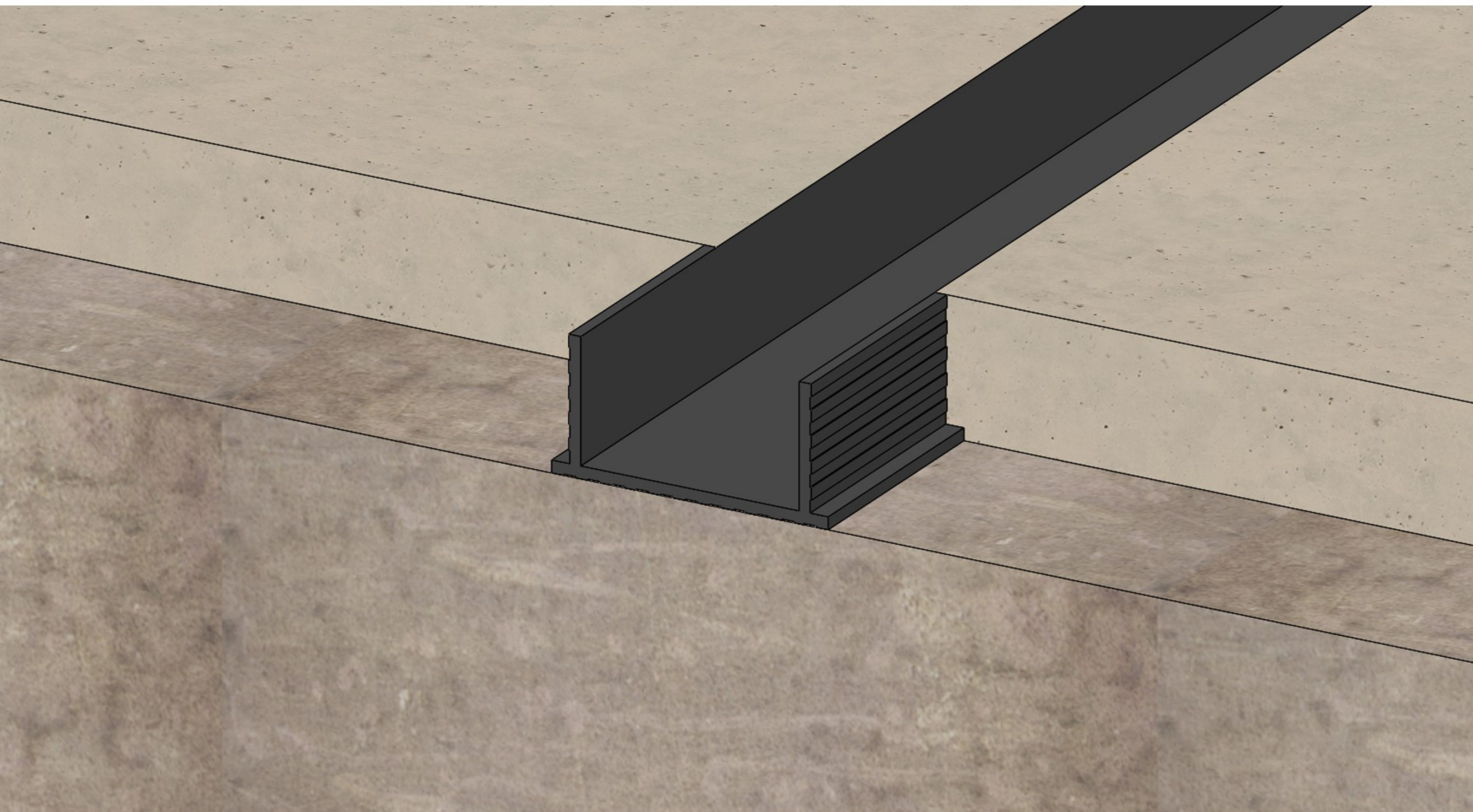

簡介：

於施作抵石、洗石、斬石時，可將此類產品先黏貼於水泥上，作為石區の間隔基準線，再進行石礫塗抹作業，「將產品翼板埋於石礫下」，即可獲得整齊美觀的石區間隔線及伸縮縫。

特色：

提高抵石、洗石、斬石的施工效率，作為牆體之間隔線與伸縮縫。



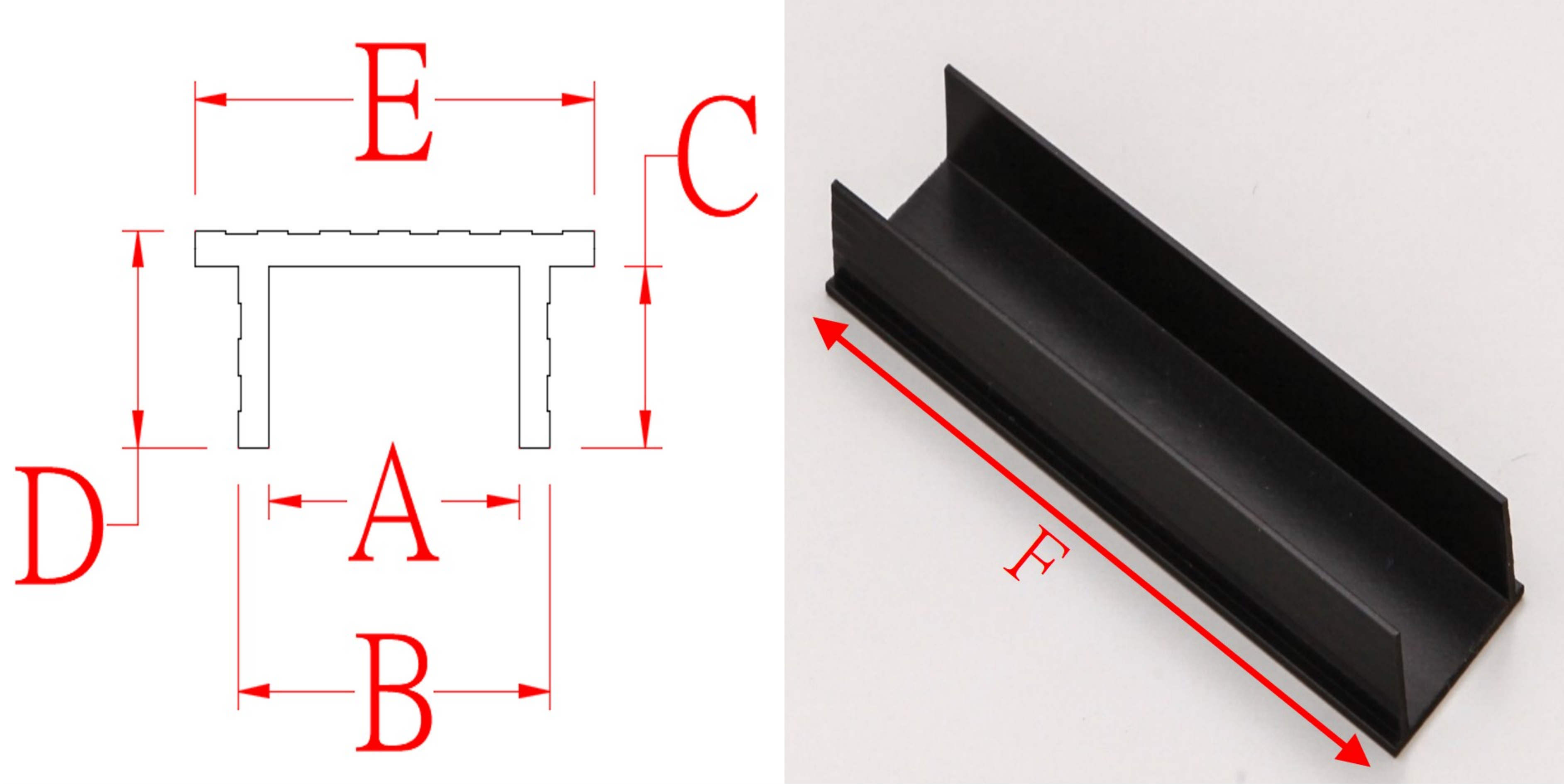

	A(mm)	B(mm)	C(mm)	D(mm)	E(mm)	F(m)
PH101	8	10	10	11	12.8	1.8
PH101B	8	10	5	6	12.8	1.8
PH175	8	10	7.5	8.5	12.8	1.8
PH102	18	20	10	11	22.8	1.8
PH102B	18	20	5	6	22.8	1.8
PH275	18	20	7.5	8.5	22.8	1.8

# ㄇ型條上蓋

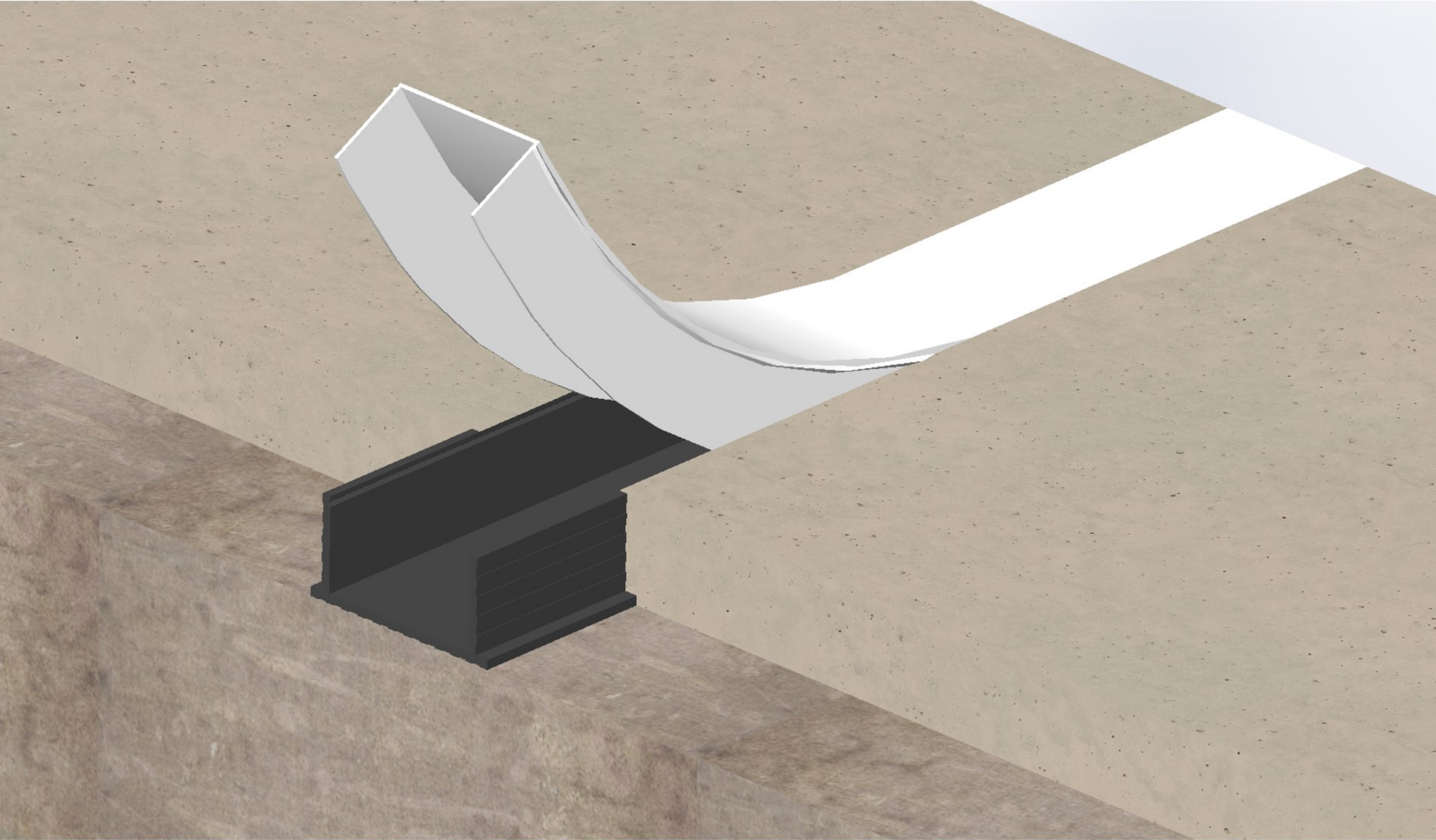

## 簡介：

在使用ㄇ型條時，需先利用海棉將中間的溝縫塞住，以免後續塗抹水泥時弄髒溝縫，待水泥塗抹完成後，再將海綿拔除。而本產品可代替海綿，且較海綿好塞好拔，以提高施作效率，還可重複利用。

## 特色：

提高抵石、洗石、斬石的施工效率，並可回收再利用。

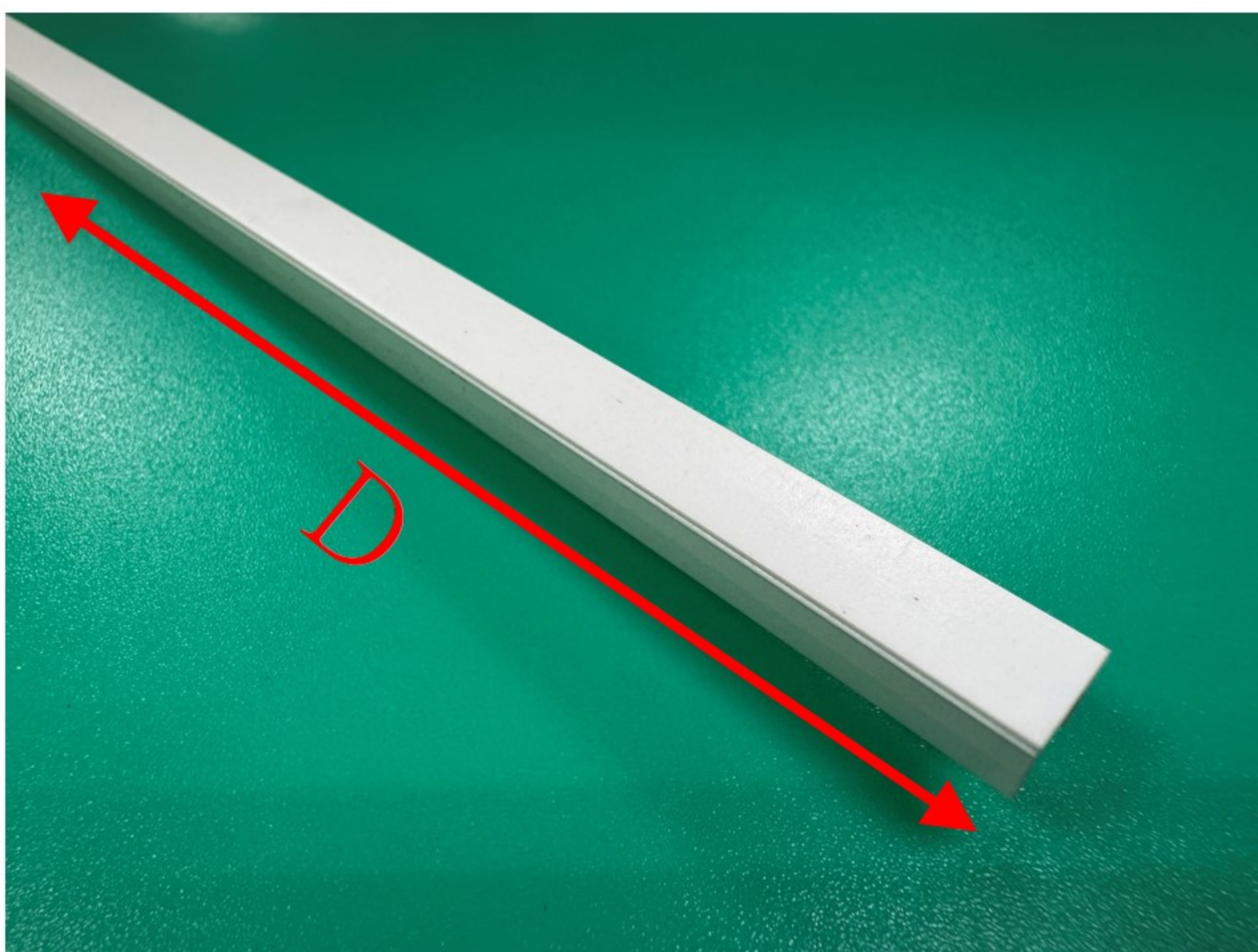
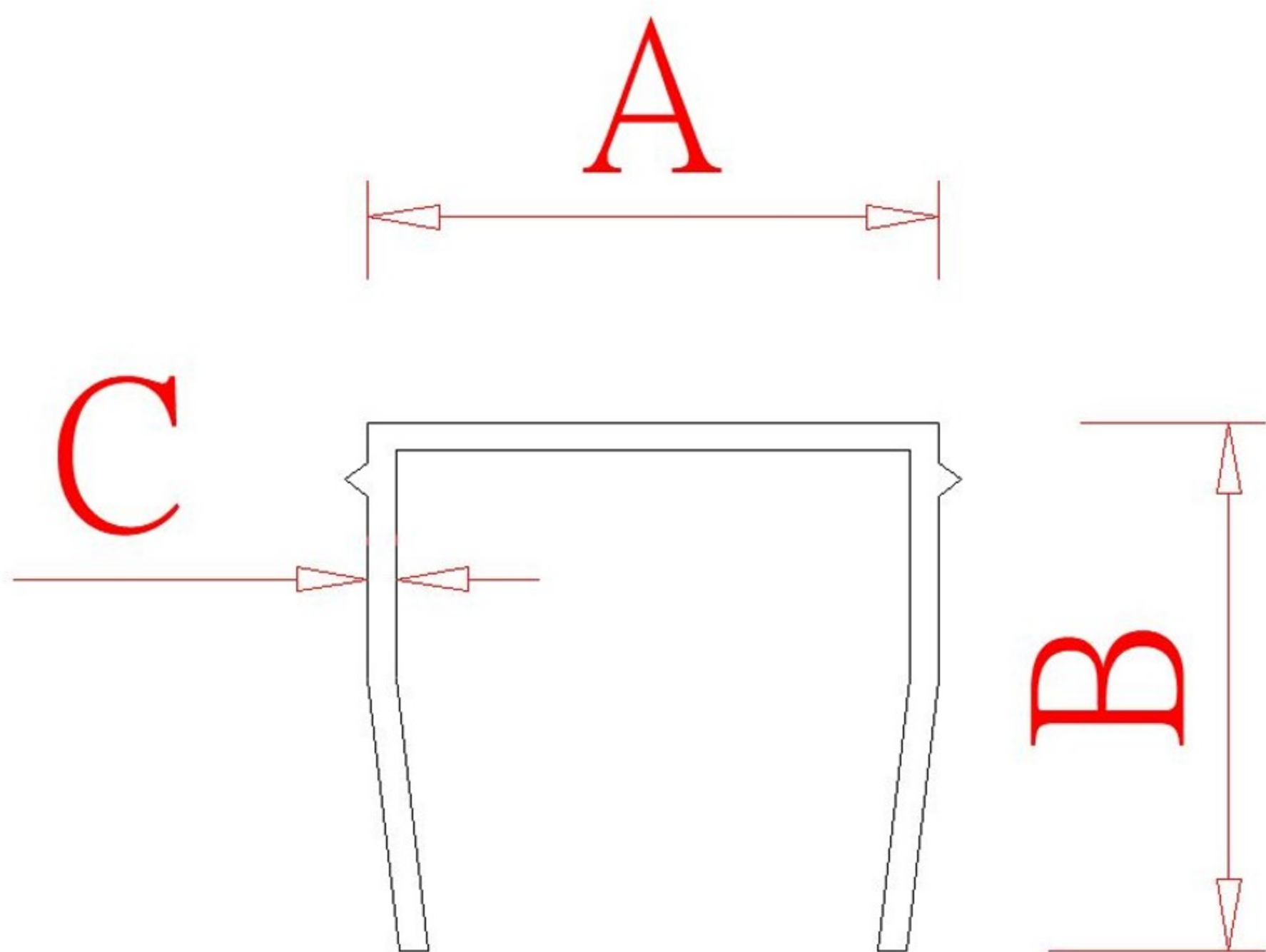

	A(mm)	B(mm)	C(mm)	D(M)
PH175PP	8	7.4	0.4	1.8

# 三光條

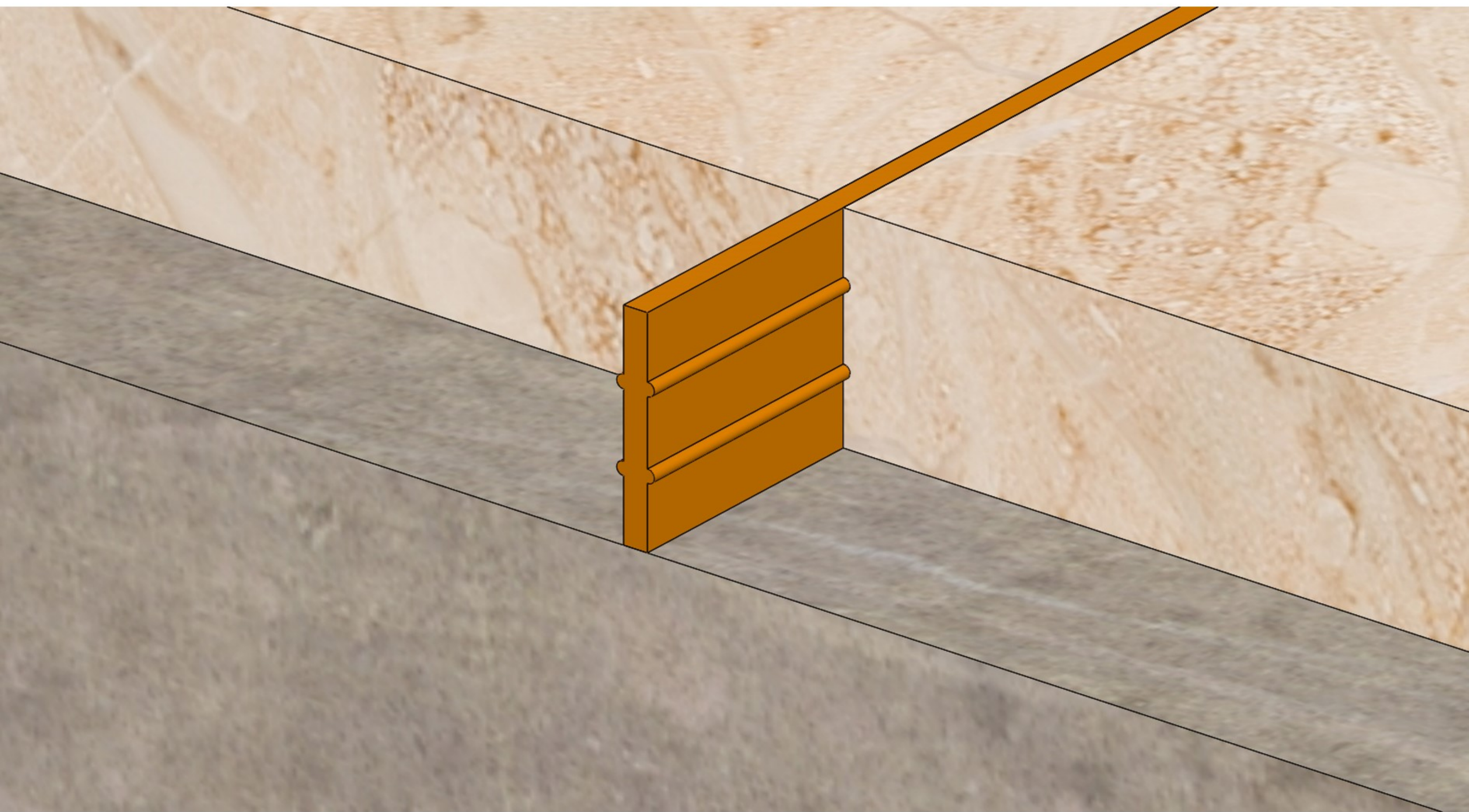

簡介：

在施作磨石工程時，為避免熱漲冷縮產生龜裂，可利用此類產品做為伸縮縫，也可作為磨石的基準線條。

特色：

避免磨石地板或牆面因熱漲冷縮產生裂縫，並可作為磨石基準線以提高施工效率

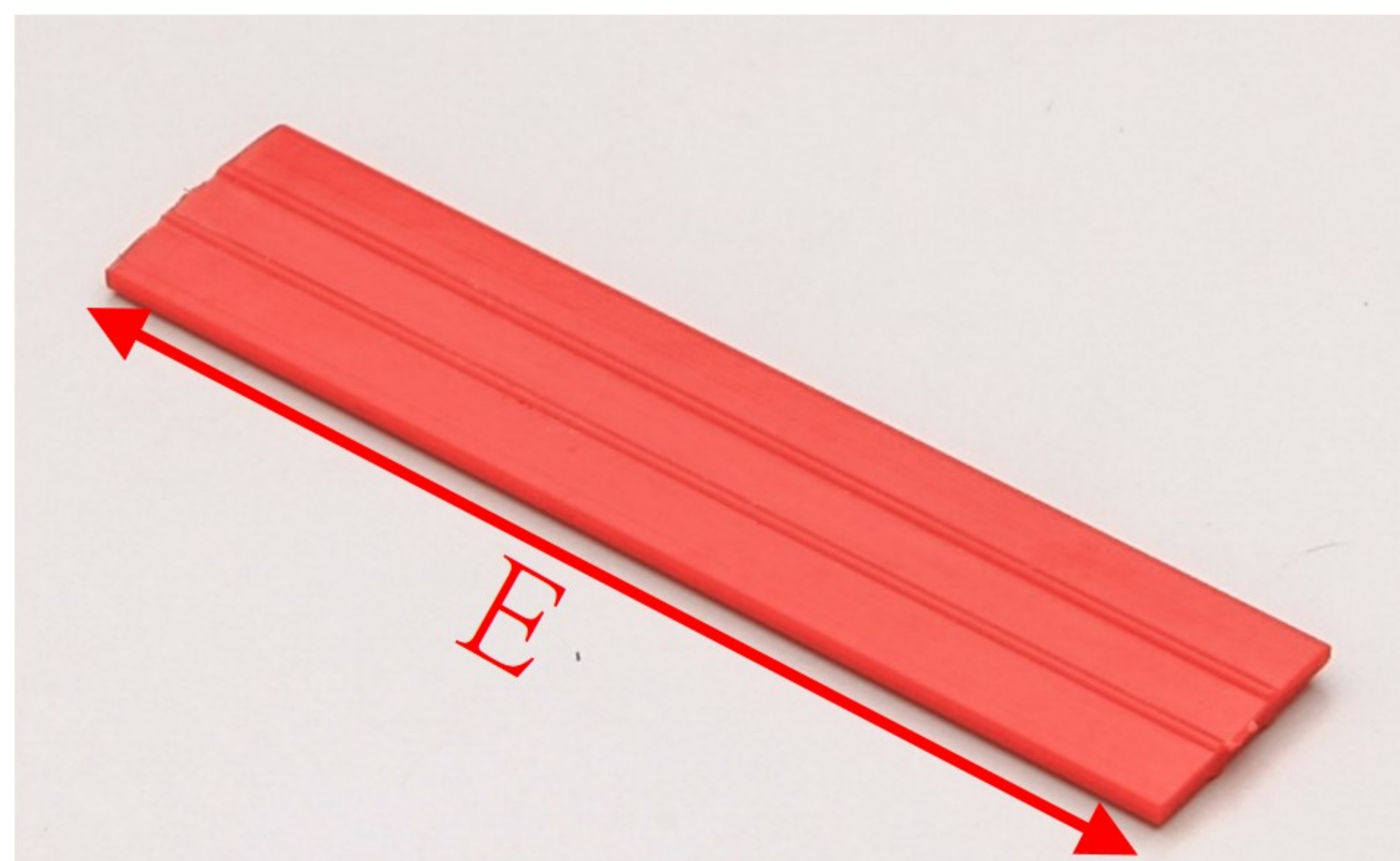
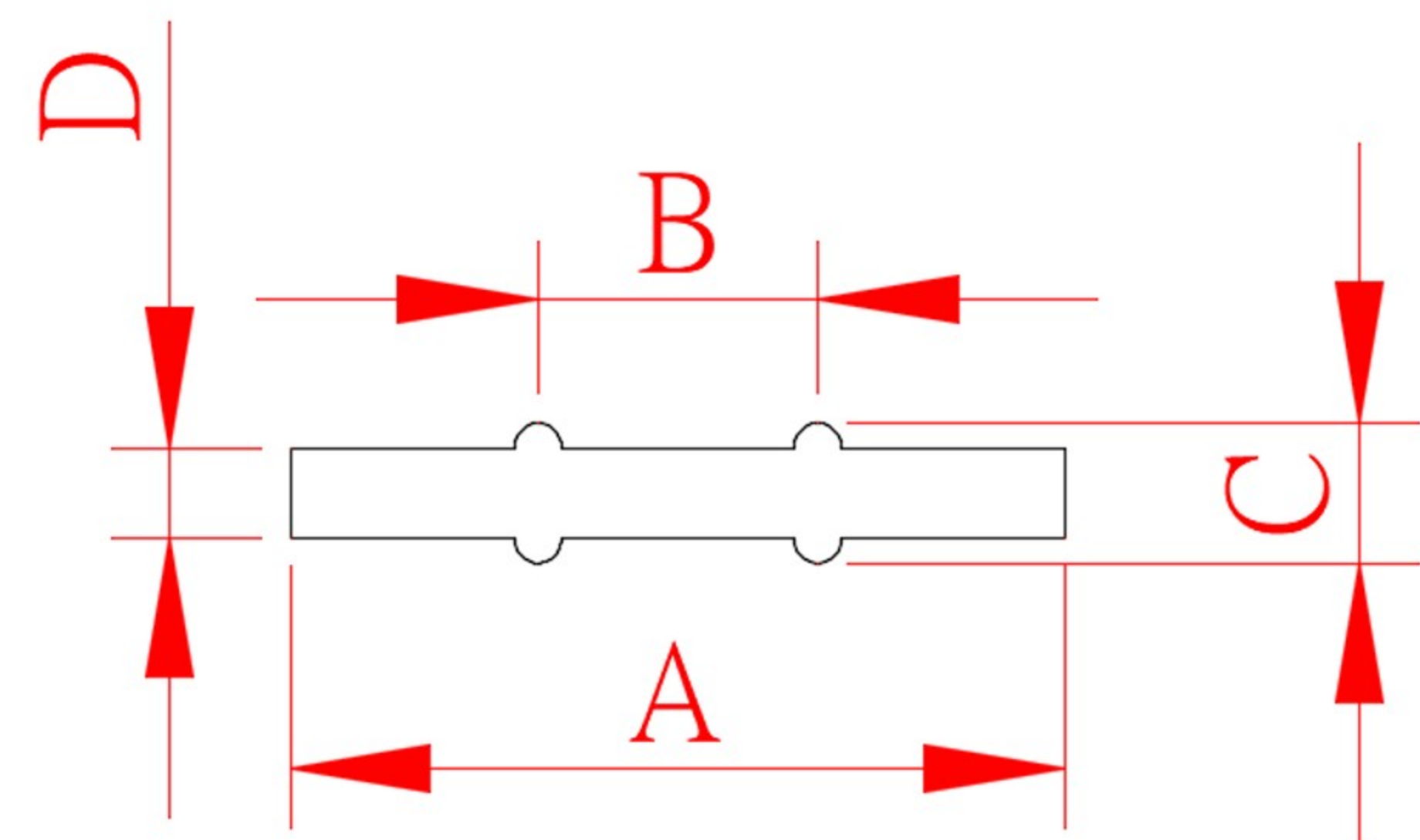

A(mm)

B(mm)

C(mm)

D(mm)

E(m)

PL001R  
(紅色)

16.6

6

3

1.9

1.0

PL001Y  
(黃橘色)

16.6

6

3

1.9

1.0

# 牆面批土伸縮縫(弧型)

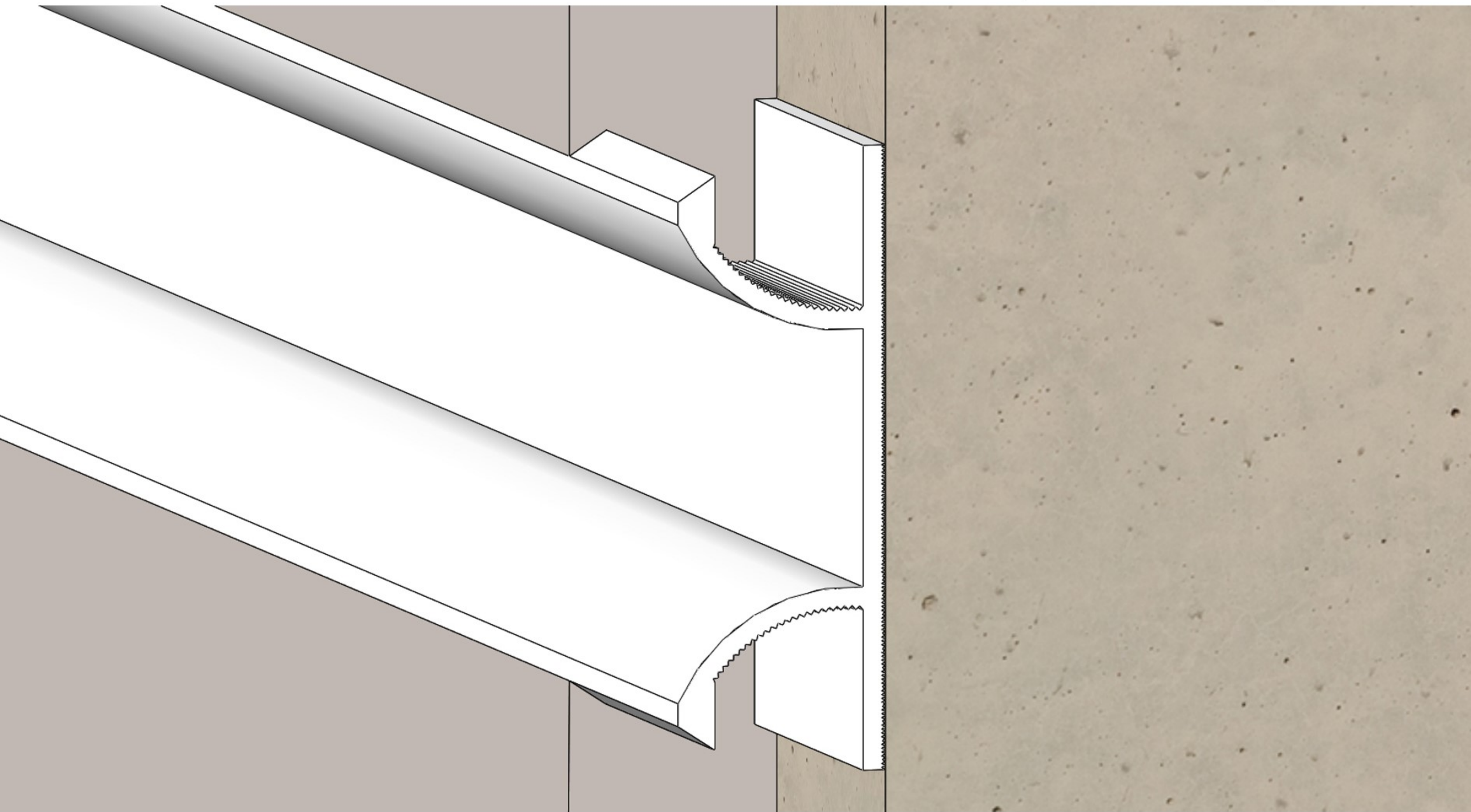

簡介：  
當牆壁、天花板等欲使用水泥或披土工程，為避免因熱膨脹而產生裂縫，可使用此類產品留下美觀的間隙作為伸縮縫。

特色：  
可提高水泥或披土工程的施工效率，作為牆體及天花板等建物之伸縮縫。

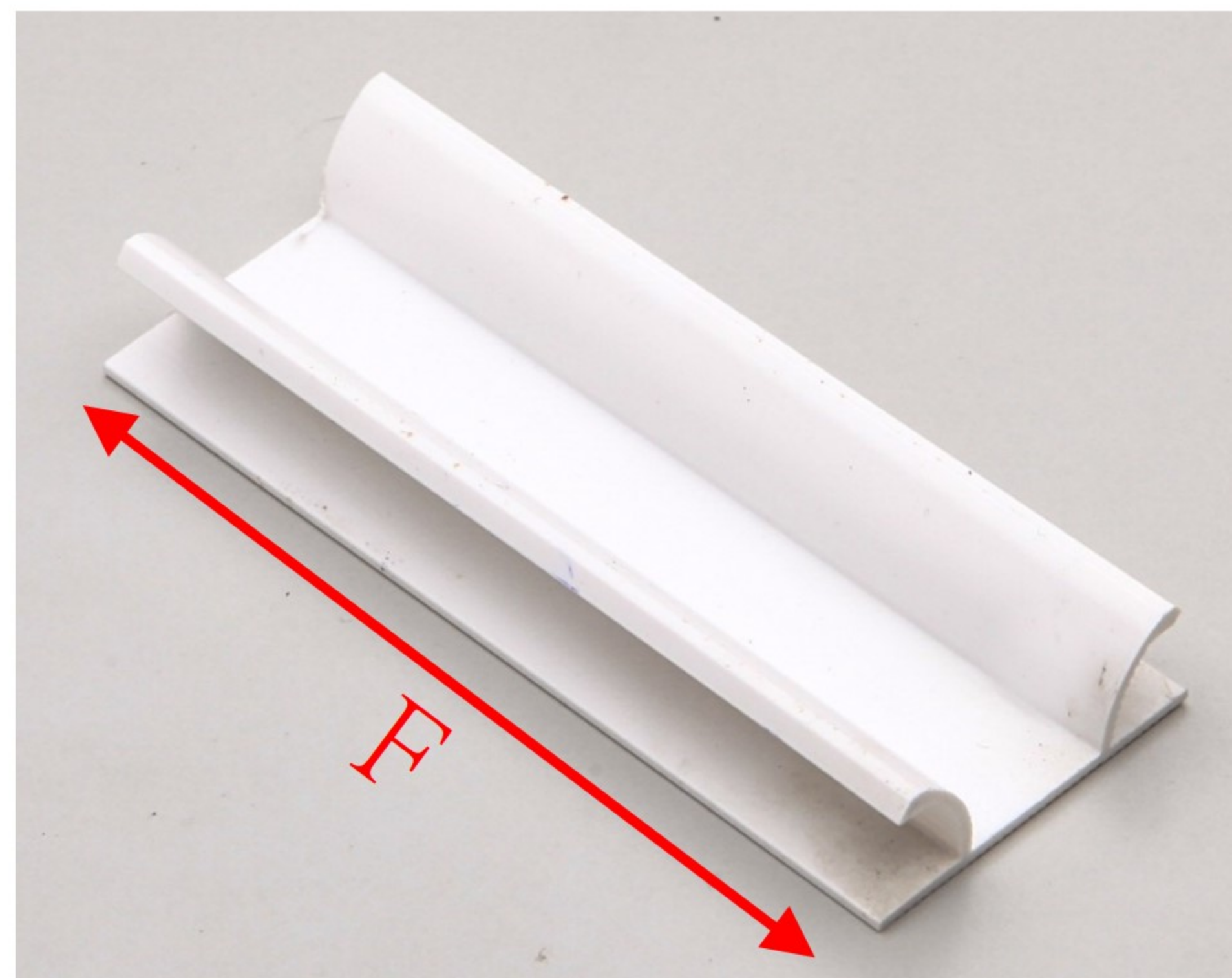
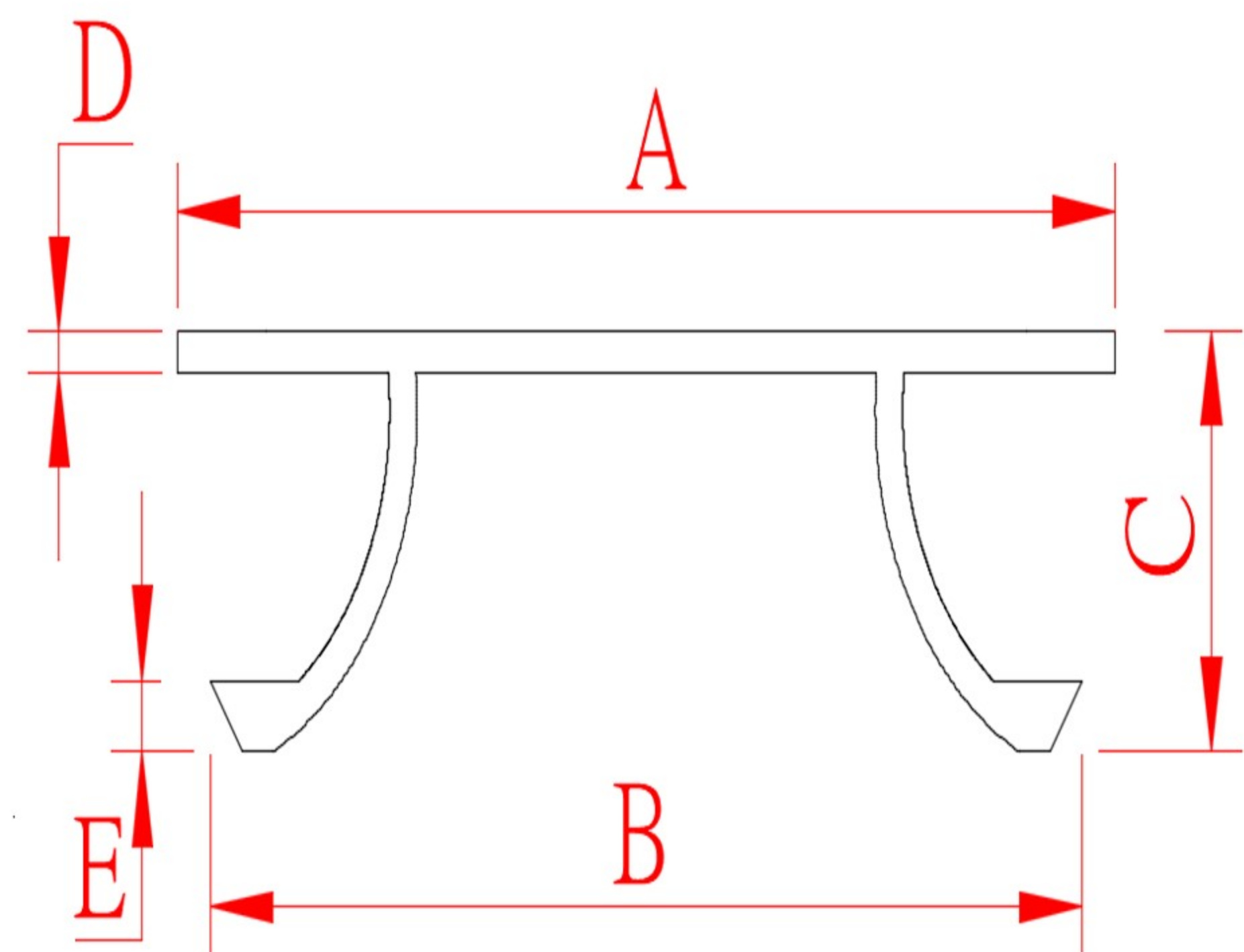

	A(mm)	B(mm)	C(mm)	D(mm)	E(mm)	F(m)
GC25	32.6	30	11.2	1.1	1.9	2.0
GC30	37.6	35	11.2	1.1	1.9	2.0

# 牆面批土伸縮縫(ㄇ型)

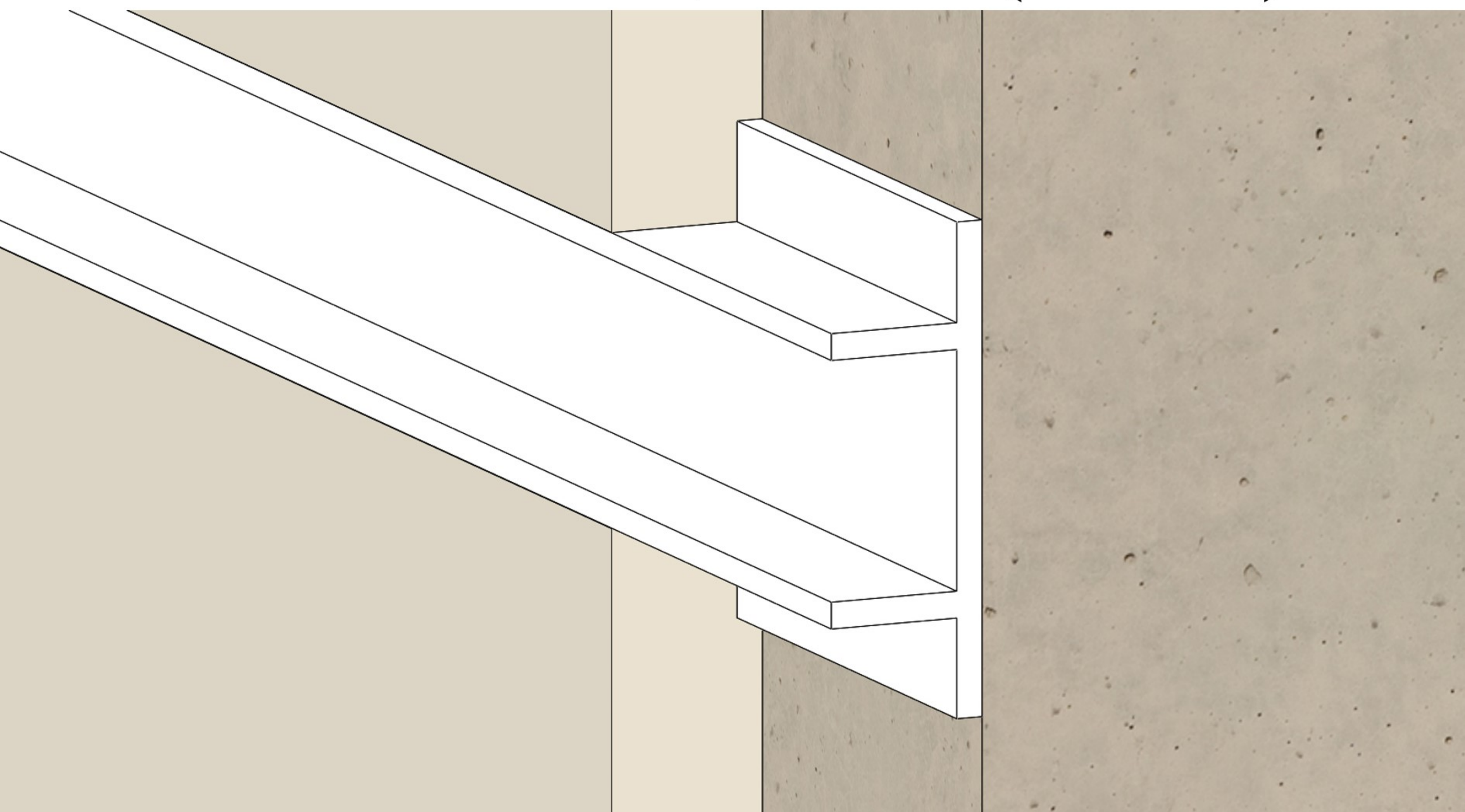

簡介：  
當牆壁、天花板等欲使用水泥或披土工程，為避免因熱膨脹而產生裂縫，可使用此類產品留下美觀的間隙作為伸縮縫。

特色：  
可提高水泥或披土工程的施工效率，作為牆體及天花板等建物之伸縮縫。



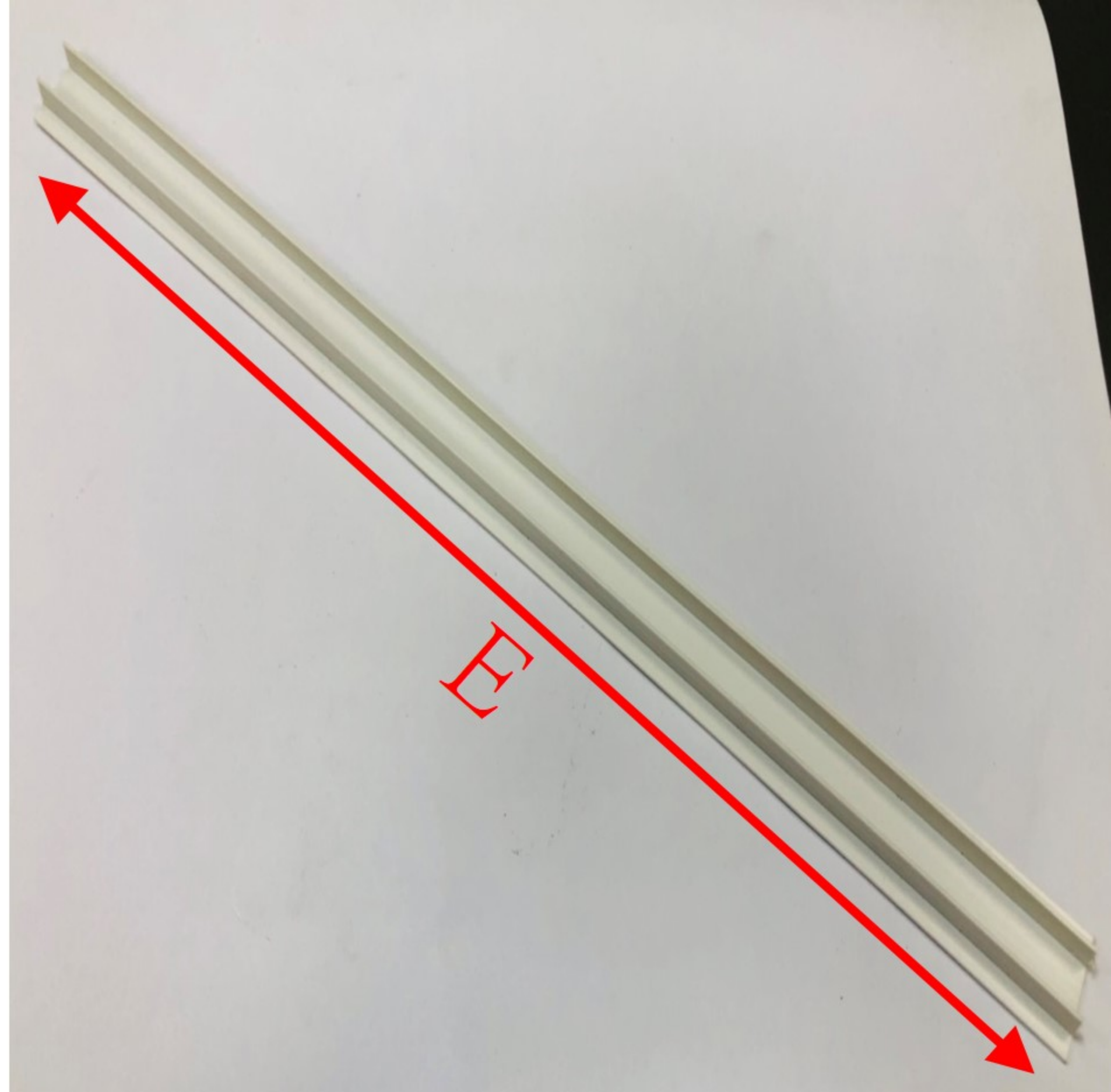
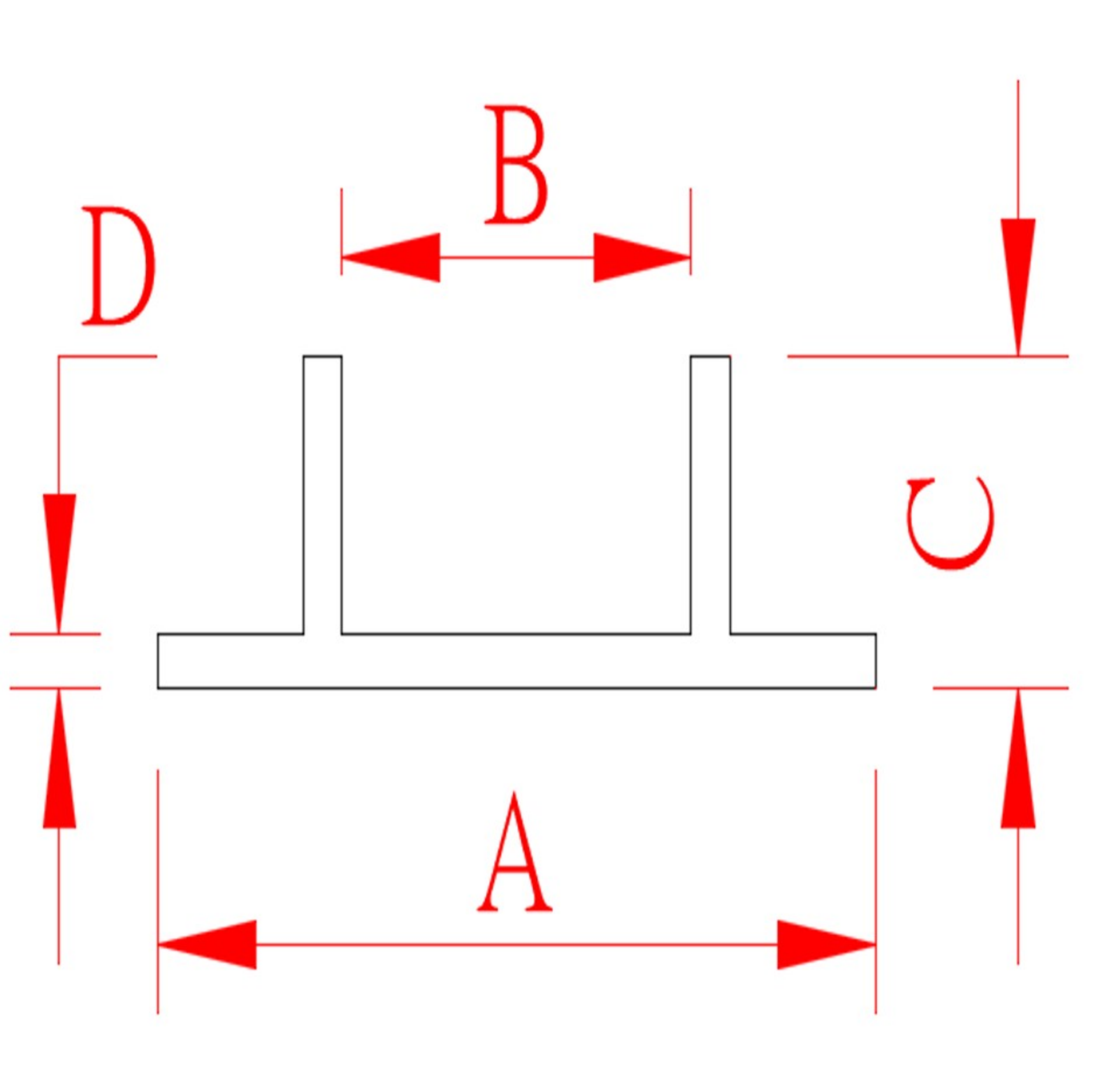

	A(mm)	B(mm)	C(mm)	D(mm)	E(m)
--	-------	-------	-------	-------	------

GU0905	18.5	9	5.6	1	2.0
--------	------	---	-----	---	-----

GU1605	24.5	17	6	1	2.0
--------	------	----	---	---	-----

# 牆面批土伸縮縫(勾型)

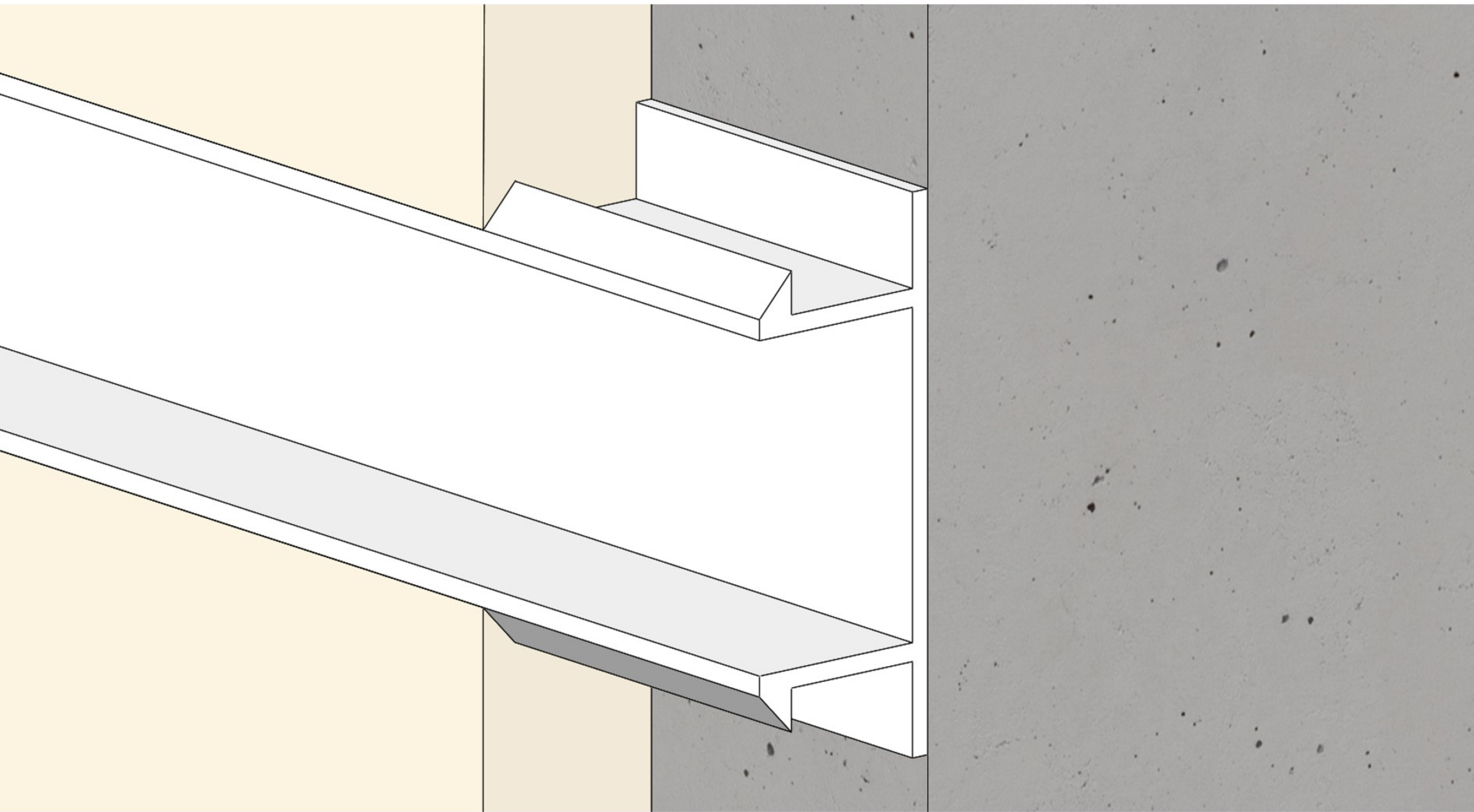

簡介：  
當牆壁、天花板等欲使用水泥或披土工程，為避免因熱膨脹而產生裂縫，可使用此類產品留下美觀的間隙作為伸縮縫。

特色：  
可提高水泥或披土工程的施工效率，作為牆體及天花板等建物之伸縮縫。

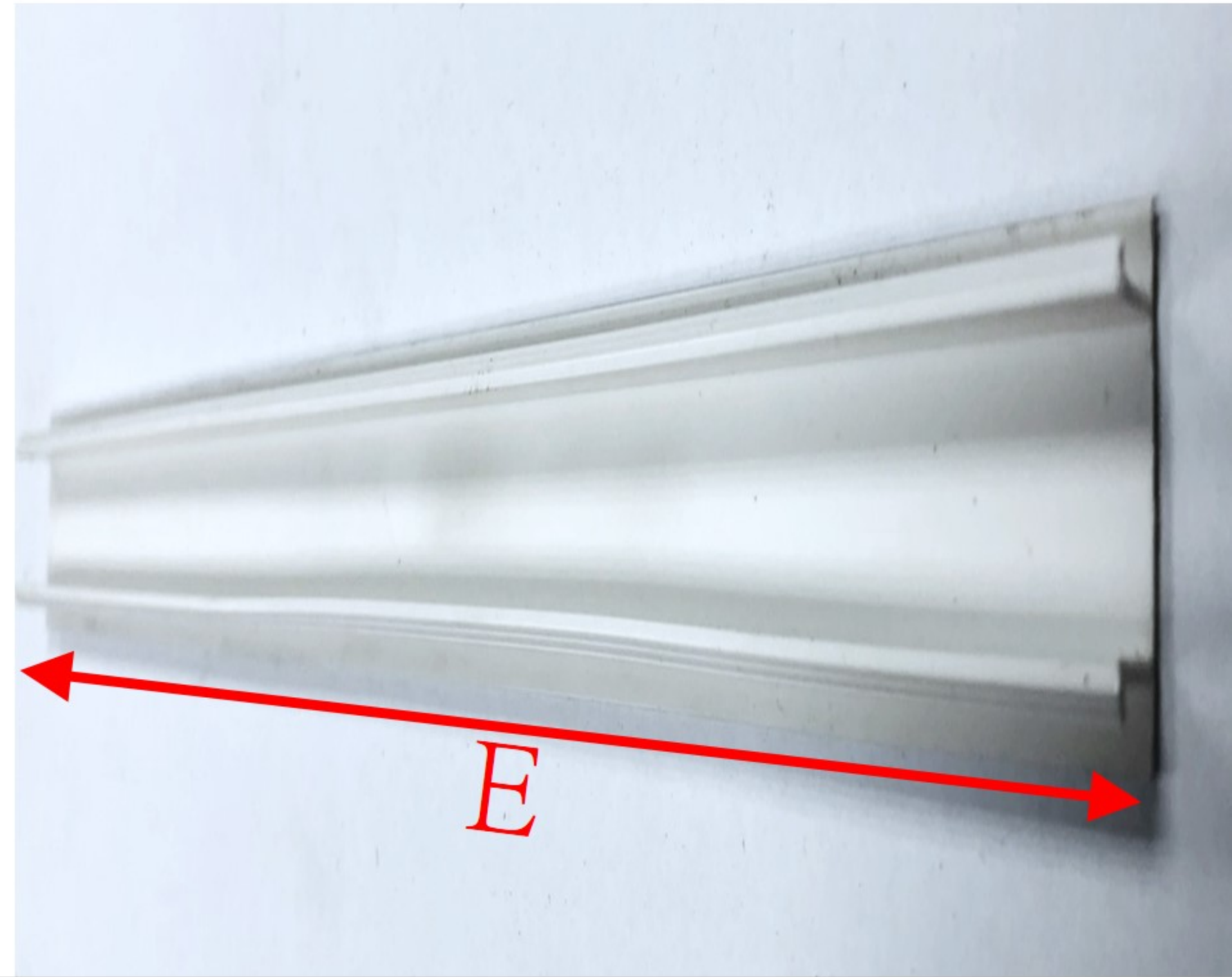
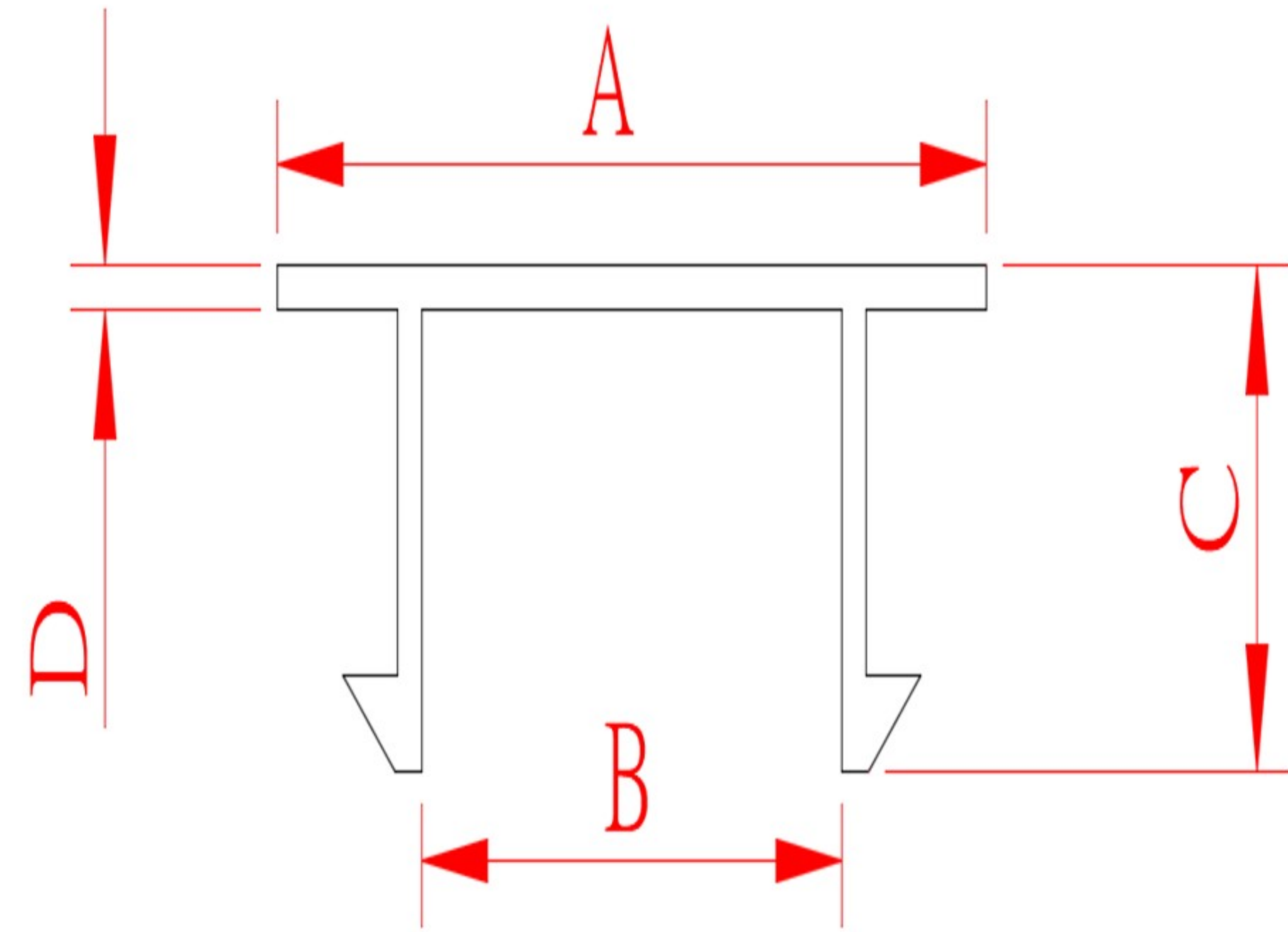

	A(mm)	B(mm)	C(mm)	D(mm)	E(m)
GU1609	27	16	10	0.9	2.0
GU2010	30	20	11	0.9	2.0
GU5010	62.6	49.6	11.3	1.1	2.0

# 牆面批土伸縮縫(V型)

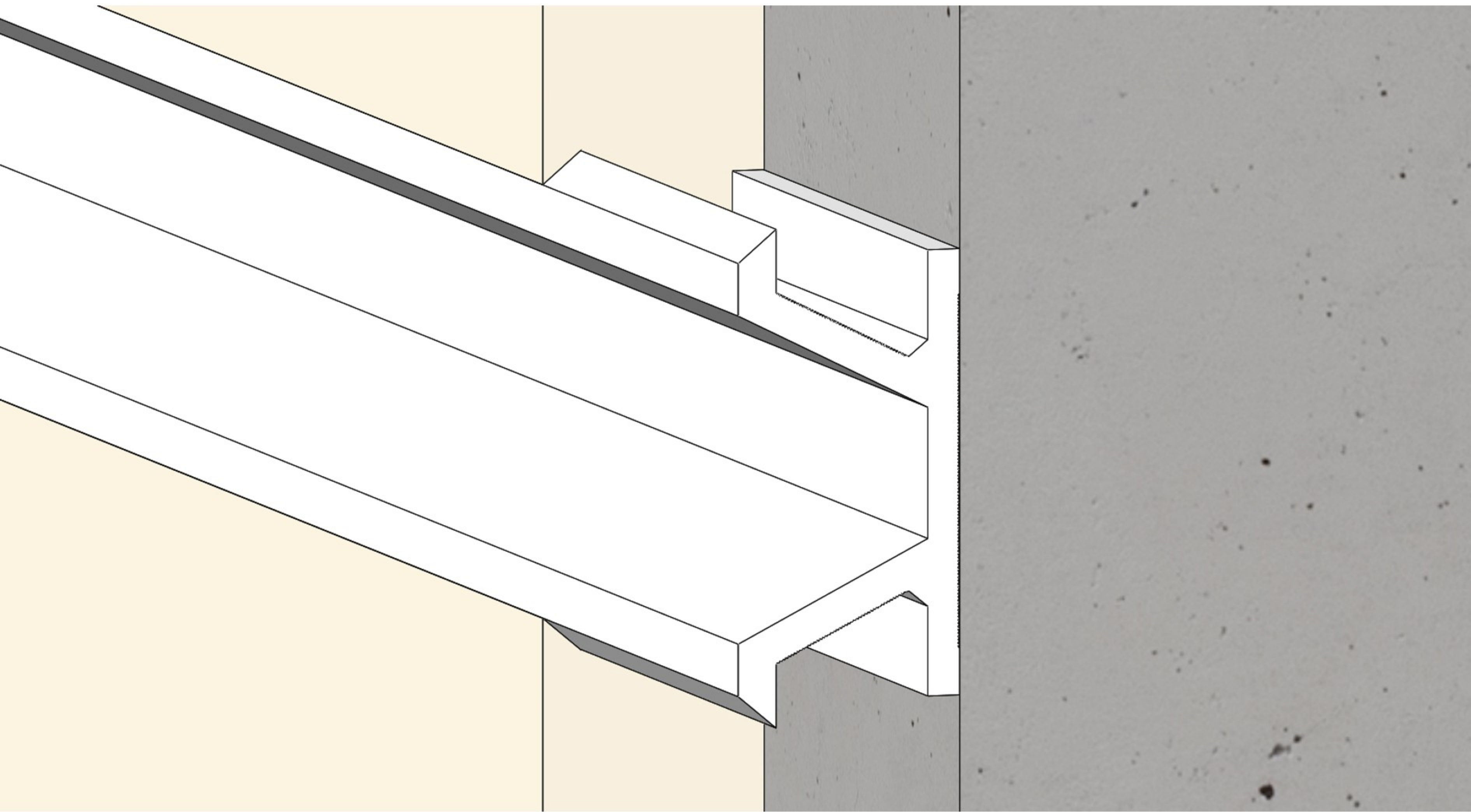

簡介：

當牆壁、天花板等欲使用水泥或披土工程，為避免因熱膨脹而產生裂縫，可使用此類產品留下美觀的間隙作為伸縮縫。

特色：

可提高水泥或披土工程的施工效率，作為牆體及天花板等建物之伸縮縫。

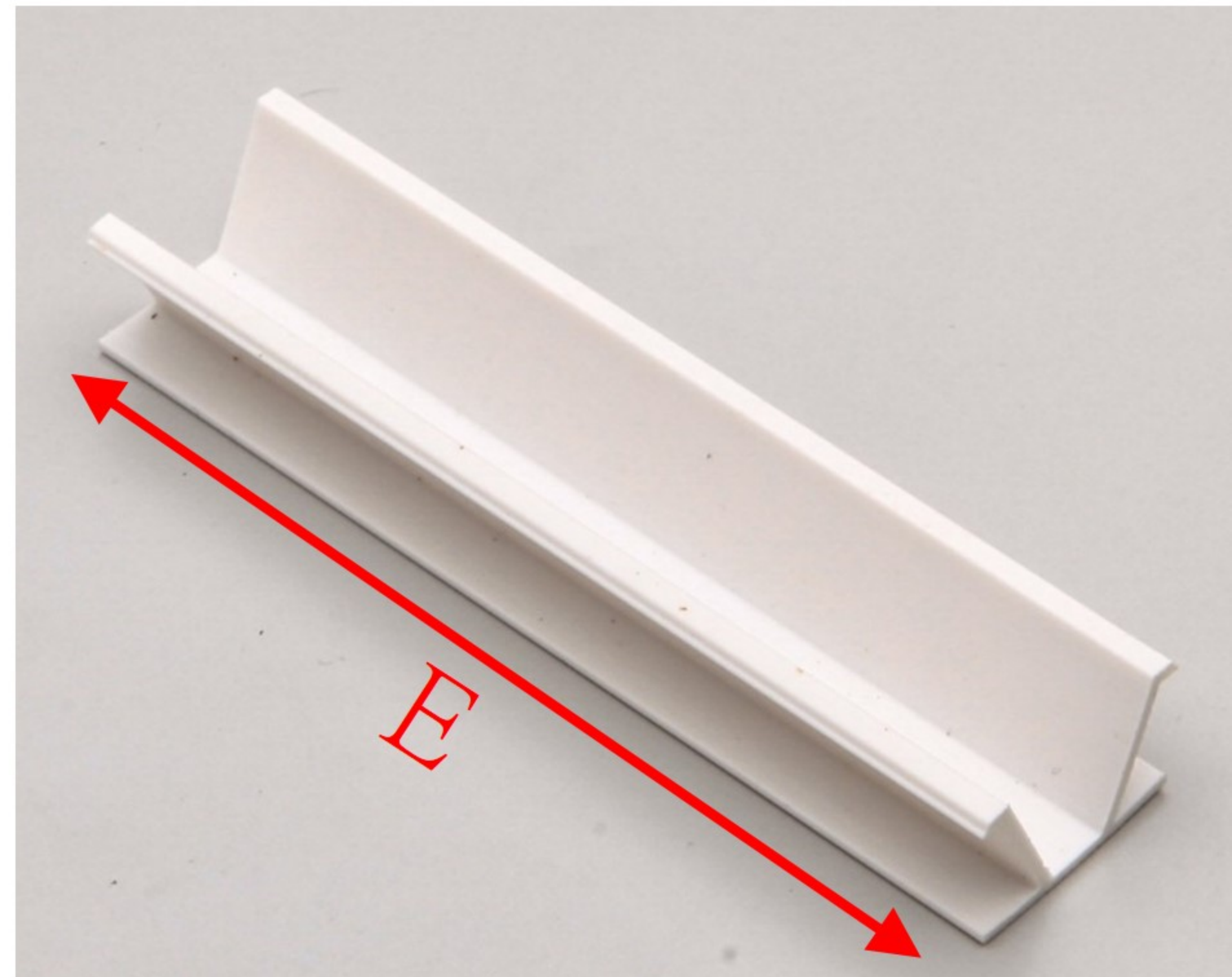
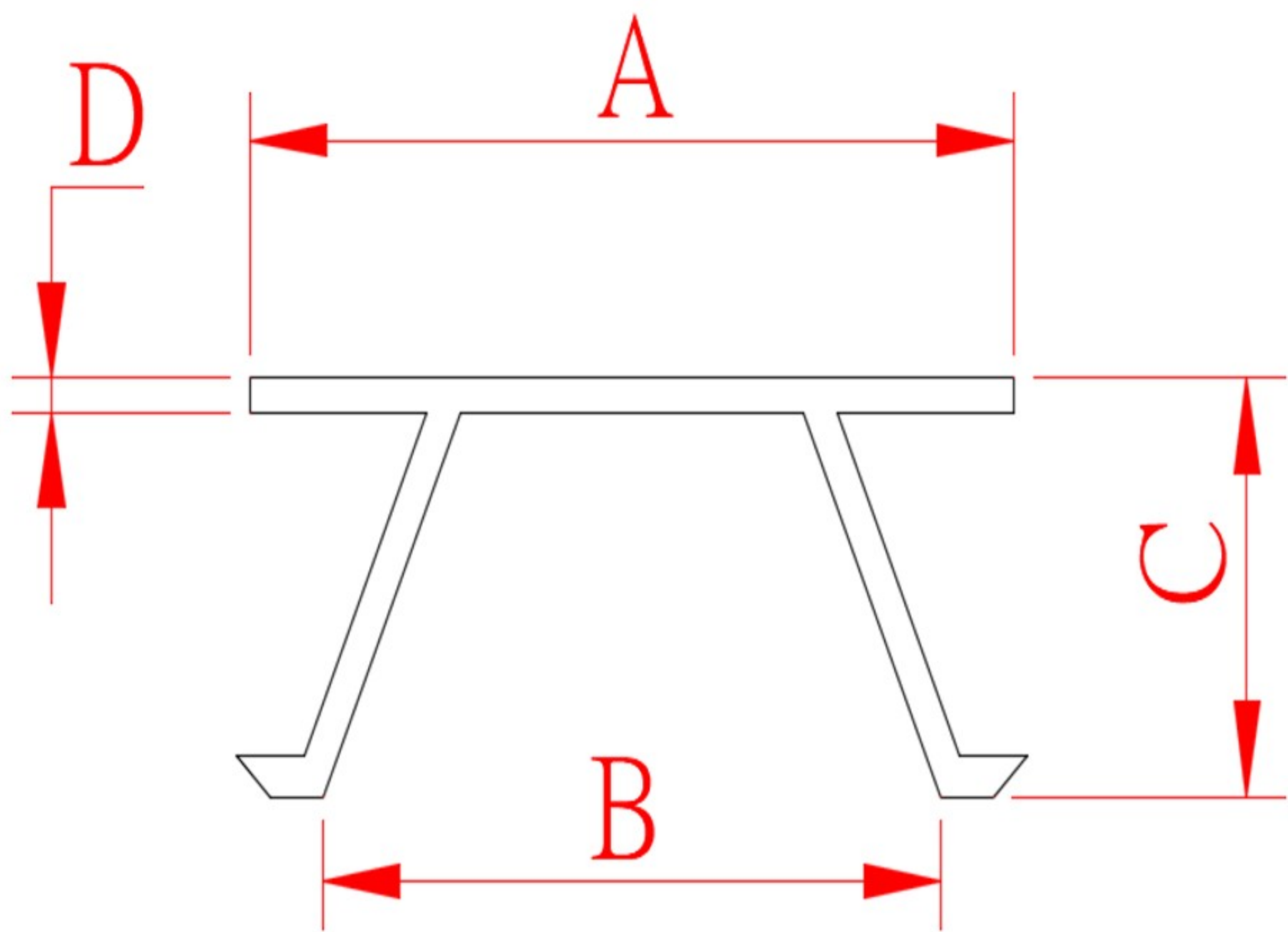

	A(mm)	B(mm)	C(mm)	D(mm)	E(m)
GV10	13.6	10	7	0.9	2.0
GV15	18.7	15	11	0.9	2.0
GV20	24.7	20	11	0.9	2.0
GV30	35.4	30	11	0.9	2.0

# 梯形條

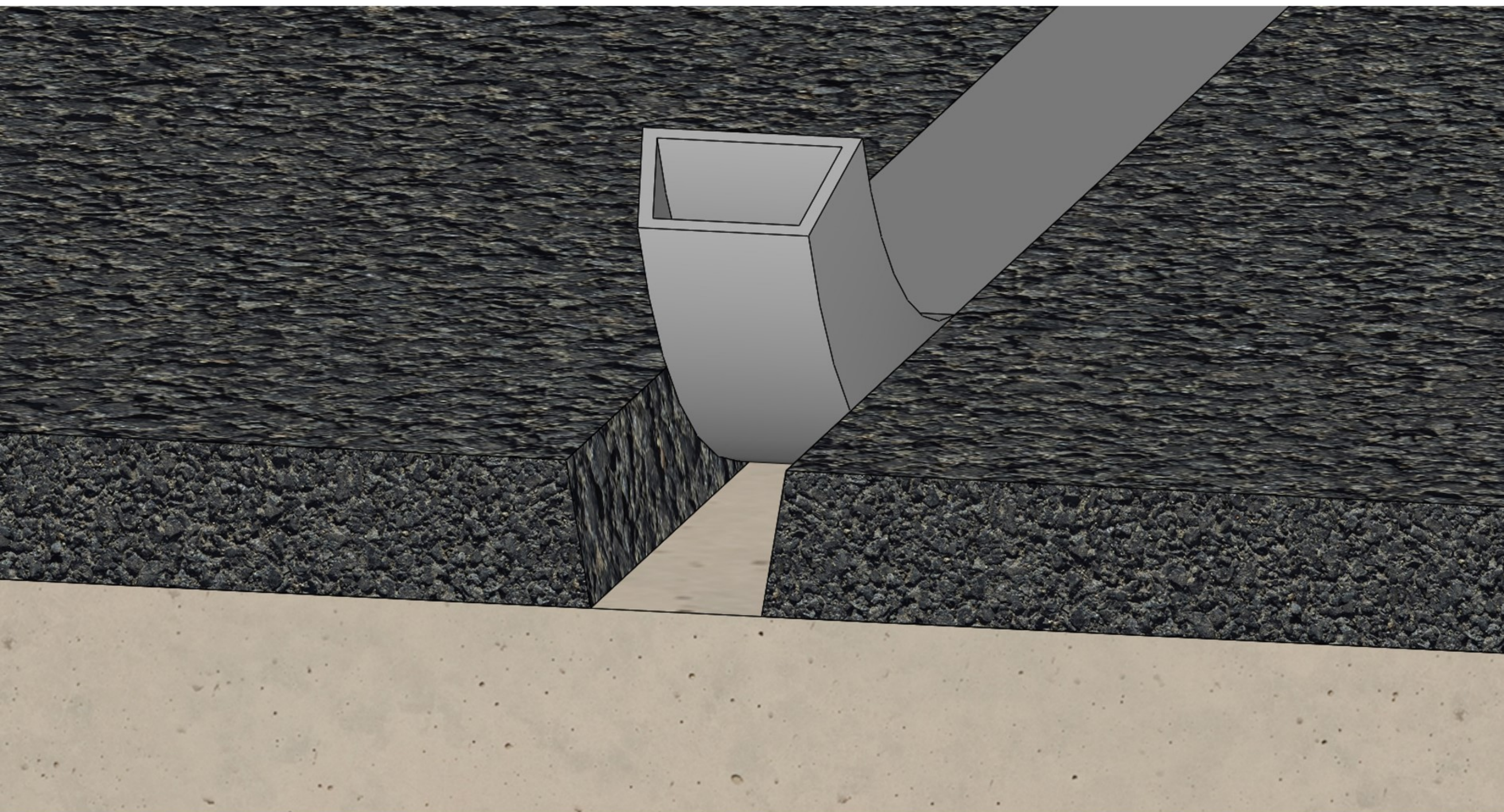

簡介：

於施作抵石、洗石、斬石時，可將此類產品先黏貼於水泥上，作為石區の間隔基準線，再進行石礫塗抹作業，「待水泥半乾後挑除此產品」，以獲得整齊美觀的石區間隔線及伸縮縫。

特色：

提高抵石、洗石、斬石的施工效率，輕鬆獲得整齊美觀的牆體間隔線與伸縮縫。

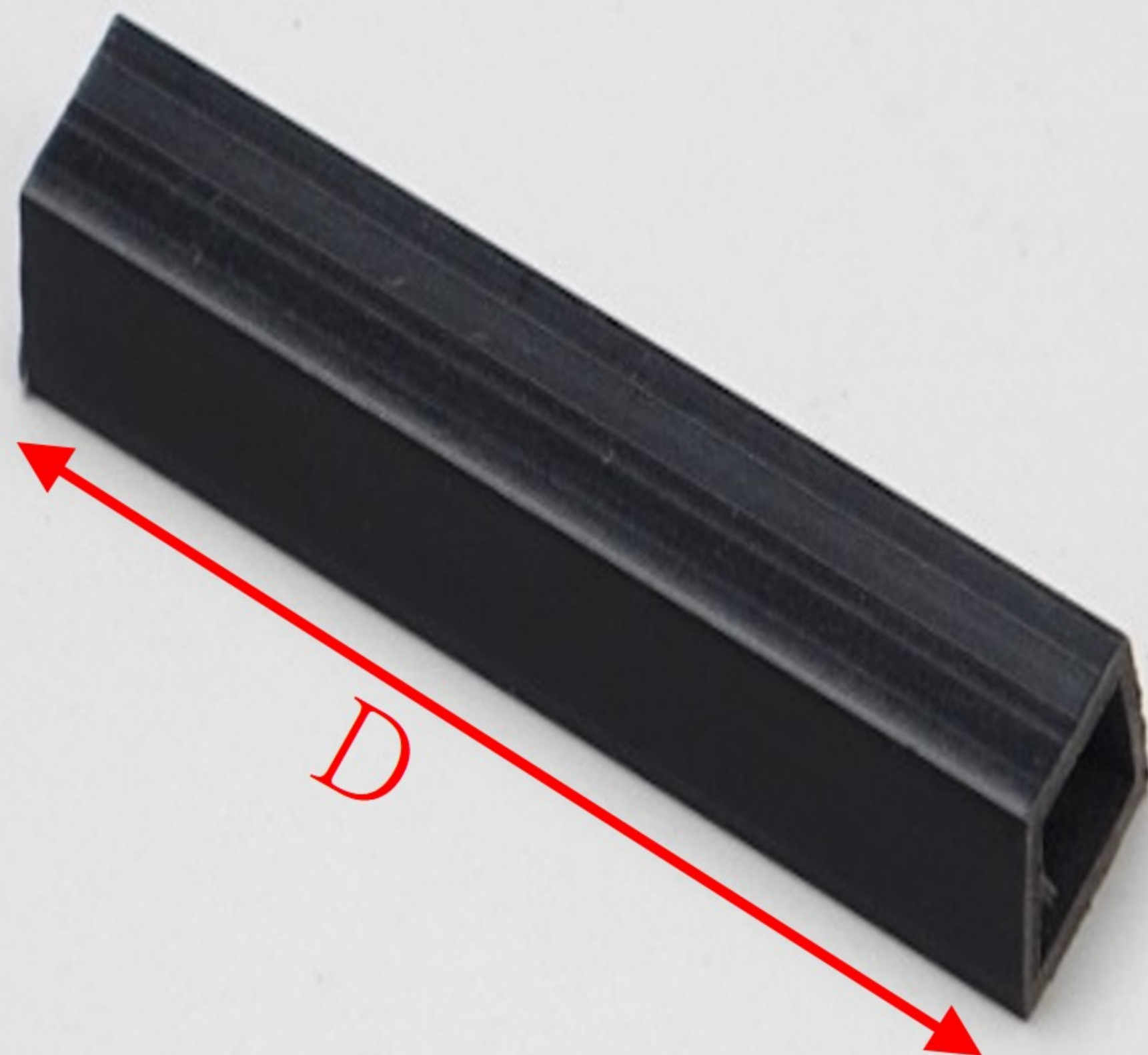
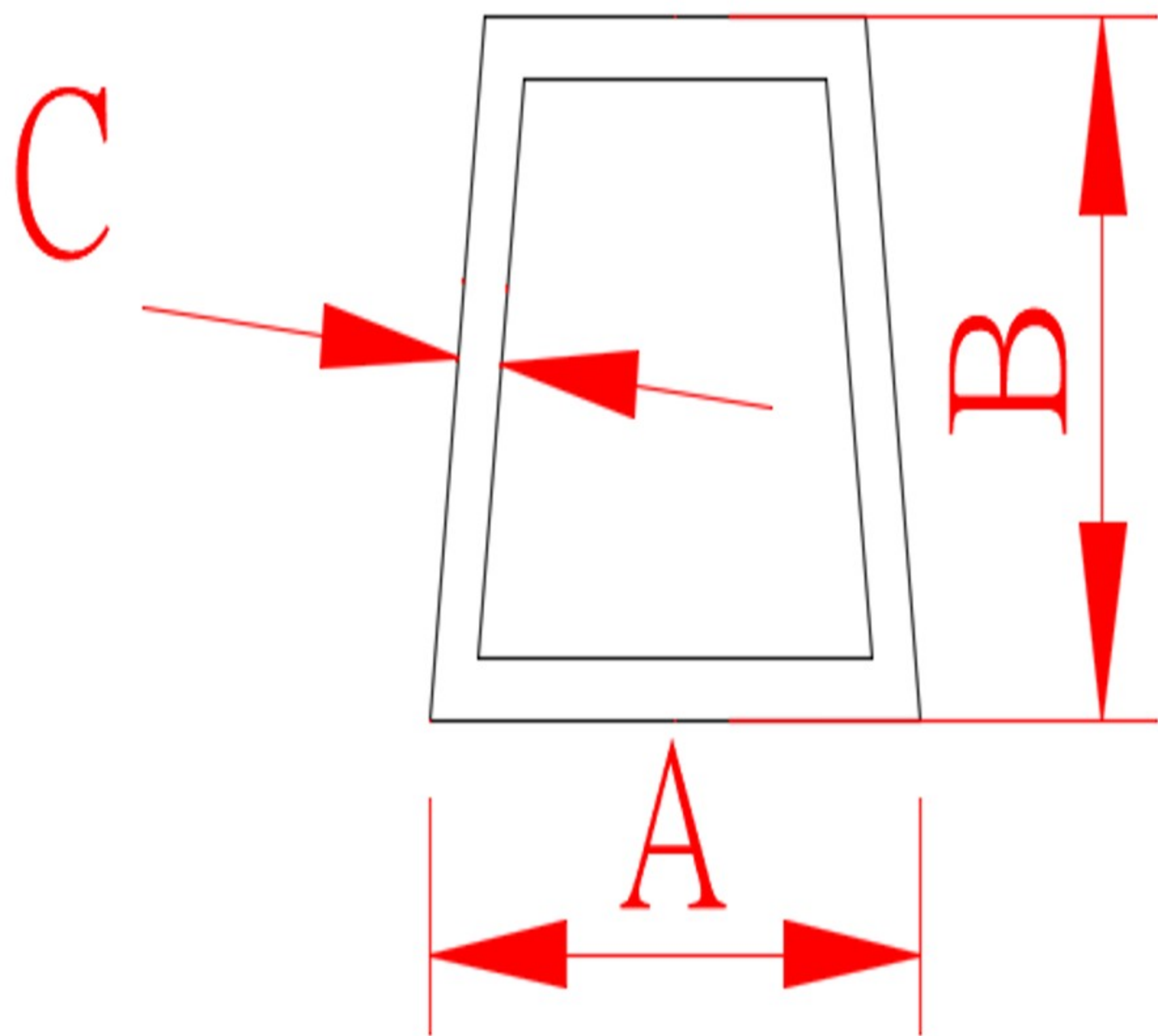

	A(mm)	B(mm)	C(mm)	D(m)
PH302	9	6	0.8	1.8
PH303	9	9	0.8	1.8
PH402	12	6	0.8	1.8
PH403	12	9	0.8	1.8
PH404	12	12	0.8	1.8
PH425	12	7.5	0.8	1.8
PH503	15	9	0.8	1.8
PH505	15	15	0.8	1.8
PH603	18	9	0.8	1.8